



Showcase Moulding, Inc.

1233 Simpson Way

Escondido, CA 92029

760-735-8746 / 760-735-8776 Fax

www.showcasemoulding.com

March 2011



We offer a wide variety of products including:

- Mirrored Wardrobe Doors
- Doors & Windows
- Columns
- Stair Systems
- Decorative Carvings
- Decorative Wall and Switch Plates
- Wood Vents
- Door Hardware
- Stains and Glues
- Cabinet Doors
- and Much More.



 **EL & EL Wood Products Corp.**





Showcase Mouldings capabilities include:

- Fireplace Mantels
- Columns
- Ceiling Medallions
- Corbels
- Onlays
- Decorative Carvings
- Stair Parts
- Cabinet Doors
- Doors
- Windows
- Exterior Louvers, Trim and



BUSINESS AND SHOWROOM HOURS

Monday - Friday 7:00 am to 5:00 pm

Saturday 8:00 am to 1:00 pm

Closed Sundays

Showcase Moulding was founded on the principle of providing the best customer service in the industry, along with the highest quality products.

With many years of experience in the lumber industry, Showcase Moulding employees will be able to assist you in all aspects of your moulding and decorative wood needs. We thank you for considering Showcase Moulding.

Showcase Moulding stocks a wide variety of mouldings in different patterns and species. We also stock specialty items such as corbels, medallions, corner blocks and plinth blocks. These items are not featured in this catalog due to the wide variety and large selection. Please stop by our showroom or call for the availability of these items.

Showcase Moulding works with numerous suppliers giving us the capability of supplying you with any special pattern you may have with short lead times on non-stock items. (Custom milling is available and requires a 50% deposit.)

Delivery is available. Please call for delivery availability and charge to your area.

Walk in and call in orders taken. All sales are C.O.D. All shipping orders are pre-paid only. All sales are taxable unless current resale information is on file.

All major credit cards are welcome. We also accept Debit cards.

Special orders require a 50% deposit and are non-returnable and non-cancelable. Suppliers may ship extra footage, customer is liable for extra footage.

All returns must be accompanied by an original sales receipt and must be returned within 30 days of purchase. Material must be in good saleable condition. All returns are subject to a restocking charge. No returns on special orders. No cash refunds.

ACTUAL SIZE AND SHAPE OF MOULDINGS MAY VARY DUE TO MILLING AND ARE SUBJECT TO CHANGE WITHOUT NOTICE

Showcase Moulding, Inc.
1233 Simpson Way. Escondido, CA 92029 Telephone (760) 735-8746 Fax (760) 735-8776

Table of Contents

Flexible Mouldings	2
Moulding Information Pages	3-8
Base	9-19
Casing	20-24
Crown Moulding	25-37
Rope & Dentil Moulding	38
Stop, Cove & Jambs	39
Quarter Rounds, Half Rounds, Full Rounds	40
Corner Moulding, Nose & Cove	41
Panel Moulding	42
Chair Rail	43
Misc, Astragal, Scribe & Batten	44
Bar Rail & Panel Cap	45
T&G Wainscott	46
Flooring Accessories	47-48
Stair Nosing	48
Brick & Stucco Mould	48
Lattice & Stool	49
Hand Rail, Treads & Stair Parts	50
Lumber	51
Plywood	52
Blocks	53
Moulding Index Page	54

HOW TO ORDER CURVED MOULDINGS:

Use part number of desired pattern, the species and add an "F" for Valufflex.

I. Casings

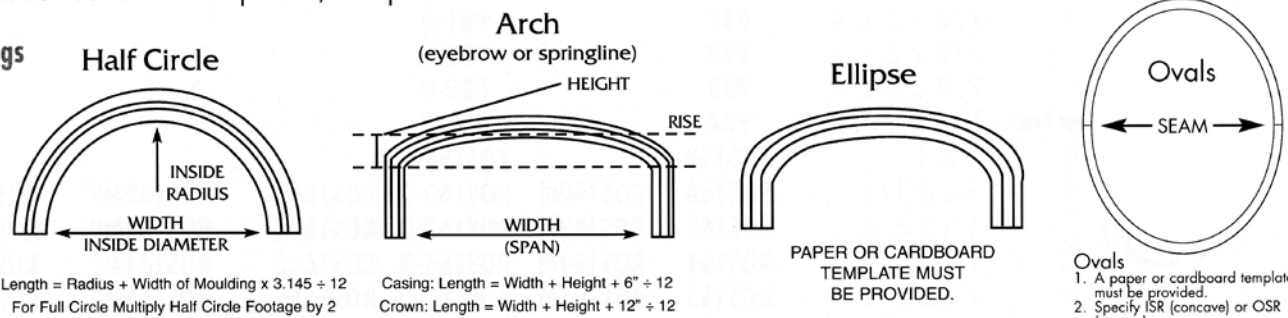

- Ovals**
1. A paper or cardboard template must be provided.
 2. Specify ISR (concave) or OSR (convex)
 3. We manufacture the FLEX so that the seams are in the middle as shown in the drawing. This allows for easier installation.

- On true half-circles, order by radius (equals 1/2 of diameter) or by diameter. Please state "Radius" or "Diameter" when ordering.
- When ordering arches, please state "span and rise" (ie: 21" span x 6" rise)
- Ellipses always require a template.

II. Crowns

- Does the wall curve inside (concave) or outside (convex)?
- Radius of wall - ISR (inside radius), OSR (outside radius).
- Length of moulding needed (add for waste) to cover entire area.
- How many pieces.

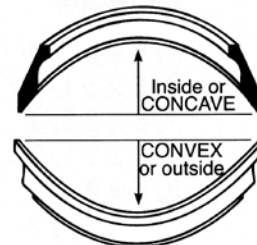

III. Crown Built Ups

- Order as ISR (Concave) or OSR (Convex) radius.
- Any moulding used on the wall: order as straight.
- Any moulding used on the ceiling: order as a radius.
 - On an OSR (outside radius), you must add the projection of the crown to the ceiling moulding radius. Example: If using the 330MUL on a ceiling with the 410MUL crown which has a projection of 4-1/2" and the wall is a 60" radius, 330MUL should be ordered as a 64-1/2" radius.
 - On an ISR (inside radius), you must subtract the projection of the crown from the radius, therefore a wall with a 60" radius less the 4-1/2" projection = 55-1/2" ISR for the 330MUL.

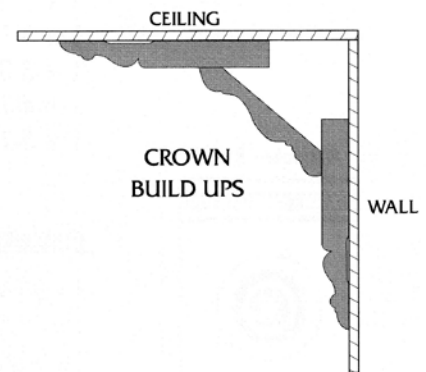

IV. Bases

- If Base is being used as Baseboard or as part of a Crown detail on a wall, the Flex Base does not need to be pre-cast to any radius. They are sold as straights and only total lineal footage is needed.
- If Baseboards are used as Casing the base must be ordered to the radius (like section I). If base is being used as part of a Crown detail where they lay flat on the ceiling (not on the wall), then information as indicated in section III C1 or C2 must be provided.

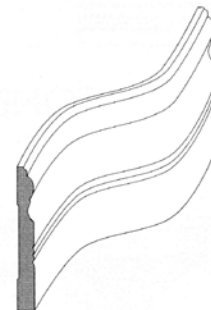

V. Panel Moulds or Lineal Moulds

- If used horizontally on curved walls, straight lengths will work.

VI. Backbands

- Radius on main casing that backband is to attach to.
- Type of curve (arch, ellipse, half-circle and information under Casings)
- Moulding part numbers, species, length, and count.

HINTS ON HOW TO FIGURE A RADIUS

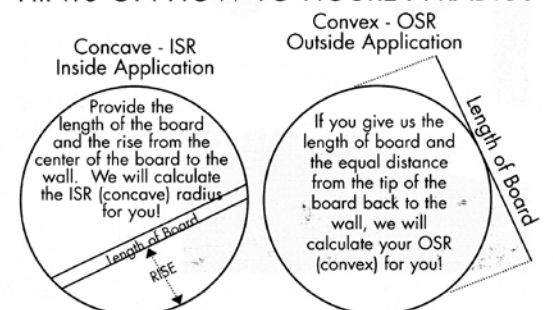

MOULDING INFORMATION AND AVAILABILITY

Baseboard

	MDF	FJ Pine	Pine	Poplar	Red Oak	White Oak	Cherry	Gen Mah	Maple	Walnut	Alder	Pecan/Hickory	Birch	Ash	DF	Santos Mah	Jatoba	Cumaru	Beech	Redwood
100		S	O	O	S	O			O				O	O	O				O	
101		S	S	O	S	S	S	S	S	S	S	S	S	O	O	S	S	S	S	
107			S	S	S				O											
111			S																	
115		S	O																	
116					S								O	O						
118		S	O	O	O	O			O											
123	S	O	O																	
127	S																			
128	S																			
132	S	S	S		S	O	O	O	S		S				O					
133		S		S	S	O			S					O						
137	S	S	S	O	S	O	O	O	S		O				O					
146	S	O																		
149	S																			
153	S	O																		
154	S						O	O	O		O									
155	S	O									O									
160	S	O		O	O		O	O	O		O									
161	S	O		O	O		O	O	O											
162	S			O							O									
165	S	O		O	O		O		O		O									
167	S	O		O	O				O											
171	S	O	O	O	O															
173				O	S															
180	S																			
184	S																			
185	S	O		O							O									
189	S			O	O	O	O	O	O	O	O									
193	S										O									
194	S	O																		
196	S										O									
200	S			S	S		O	O	O											
202	S			O	O	O	O	O	O	O	O	O	O							
210	S																			
212	S	O	O	O	S	O	O	O	S	O	O	O	O							
214	S	O	O																	
220	S																			
255	S				O		O	O	O											

S = In Stock O = Special Order

MOULDING INFORMATION AND AVAILABILITY

Casing & Chair Rail

	MDF	FJ Pine	Pine	Poplar	Red Oak	White Oak	Cherry	Gen Mah	Maple	Walnut	Alder	Pecan/Hickory	Birch	Ash	DF	Santos Mah	Jatoba	Cumaru	Beech	Redwood
302		S			O															
306	S	O	O		O								O	O						
315	S																			
322	S	O	O	O	O			O	O		O									
324	S	O	S	O	S		S	O	O		O				O					
327	S	O	O																	
331	S		O																	
333	S		O																	
340	S	O																		
341	S				O															
343	S																			
345	S	O																		
346		S	S	O	O			O	O											
350			S																	
356	S	O									O									
360	S	O	O		O				O		O									
365	S	O	O	O	O				O											
371	S																			
374	S																			
380	S	O																		
381	S	O		O	O		O	O	O											
400	S			O	O		O	O	O		S									
401	S										O									
410	S	O	O	O	O		O	S	O											
415	S			O	O	O	O	O	O	O	O									
417	S	O		O	O		O	O	O		O									
420	S	O	S	O	S	O	O	O	O	O	O	O	O		O					
421	S	O	O	O	O	O	O		O	O	O									
422	S	O	O	O	O															
425	S																			
436	S																			
447	S																			
450	S																			
470	S				O		O	O	O											
493	S	O	O		O															
494				O	S		O	O	O		S									
495	S			O	O	O	O	O	O	O	O									
498	S			O																
754	S	O	O	O	S				O											
755	S																			
760	S	O	O	O	O	O	O	O	O	O	O									
762	S	O		O	O	O	O	O	O	O	O									

S = In Stock O = Special Order

MOULDING INFORMATION AND AVAILABILITY

Crown

	Redwood	Birch	Cumaru	Jatoba	Samba Mah	DF	Ash	Birch	Peanut/Hickory	Alder	Walnut	Maple	Gen Mah	Cherry	White Oak	Red Oak	Poplar	Pine	FJ Pine	MDF	
500																					
504																					
508																					
509																					
510																					
511																					
512																					
513																					
514																					
515																					
516																					
518																					
519																					
525																					
527																					
530																					
531																					
532																					
539																					
542																					
543																					
544																					
550																					
551																					
552																					
557																					
560																					
570																					
572																					
573																					
580																					
581																					

S = In Stock O = Special Order

MOULDING INFORMATION AND AVAILABILITY

Stop, Corner, Round, Cove & Panel

	MDF	FJ Pine	Pine	Poplar	Red Oak	White Oak	Cherry	Gen Mah	Maple	Walnut	Alder	Pecan/Hickory	Birch	Ash	DF	Santos Mah	Jatoba	Cumaru	Beech	Redwood
623		S	S	O	S		O	O	O				O	O						
624	S	O																		
635		S	S																	
640	S	O	O	S	O						O									
651			S	O	S	O	O	O	O	O	O		O	O						
654		O	S	O	S	O	O	O	S	O	O	O	O	O						
657			S																	
660			S		S				S					O	O					
661			S	O	S	O	O	O	S	O	O		O	O						
662			S																	
663			S	O	O	O*	O	O	O	O*	O*									
670			S	O	O		O	O	O	O	O									
671			S	O	O	O	O	O	O	O	O									
672			S	O	S	O	O	O	S	O	O		O	O						
675		S	S	O	S	O	O	O	S	O	S	O	O	O		S	S			
676			S	O																
680			S	O																
681			S																	
682			S	O	O	O	O	O	O	O	O		O							
683			S	O	O	O	O	O	O	O	O		O							
694				O	O										S					
695				O	O				O						O					
699				O	O				O											
700				S	S	O	S	O	O	O	S	O	O							
702				S	S				O											
720			S		O															
722		O	O	O	O				O		S									
730			S																	
767				S	S				O											O
769	S			O	O															
770			O	S	O	O	O	O	S	O	S	O	O							
771			O	S	O	O	O	O	O	O	S	O	O							
775				S	O	O	O	O	O	O	O									
776	S		O	S	S	O	O	O	O	S	O									

S = In Stock O = Special Order

MOULDING INFORMATION AND AVAILABILITY

Flooring Accessories

	MDF	FJ Pine	Pine	Poplar	Red Oak	White Oak	Cherry	Gen Mah	Maple	Walnut	Alder	Pecan/Hickory	Birch	Ash	DF	Santos Mah	Jatoba	Cumaru	Beech	Redwood
830					S															
831					S															
833					S															
838					S	S	S		S	S		S				S	S			
839					S	S	S		S	S		S				S	S			
841					S	O			S								O			
842					S	O	O		S	O		O					O			
843					S	O	O		S	S	O	S		O			S		O	
846					S	O			S	S		S					S			
847					S	O			S								O			
848					S	S	O		S	S	O	S		O		S	S			

S = In Stock O = Special Order

MOULDING INFORMATION AND AVAILABILITY

Misc, Astragal, Batten Scribe Etc

	MDF	FJ Pine	Pine	Poplar	Red Oak	White Oak	Cherry	Gen Mah	Maple	Walnut	Alder	Pecan/Hickory	Birch	Ash	DF	Santos Mah	Jatoba	Cumaru	Beech	Redwood	
800	S	O	S	O	O				O		O		O		O						
802					S								O		S						
803					S										S						
812		S	O		O			O			O										
813		S	O		O			O			O										
814		S			O			O													O
856			S																		
858			S																		
859			S																		
860			S																		
863			S																		
864	S		S																		
865	S		S																		
870			S																		
875				S																	
876				S																	
878	S																				
880	S																				
882	S																				
883	S																				
900			S	O	S	S	S	S	S	S	S	S	S	O			S				
901			S	O	S		O	O	O				O	O							
902				S	S				S				O								
909			S																		
911			S		O																
912			S	O	O	O	O	O	S	O	S	O	O								
919				S	S				S												
920			S	O	O	O	O	O	O	O	O	O									
925			S																		
930					S				S		O										
932				S	O																
933				O	S		O		S		O										
974					O										S						
990	S	O	O	S	O			O	O		O										
RM12				S	S	O	O		S	O	S	O		O							
RM34				S	S	O	O		S	O	S	O		O							
RM38				S	S	O	O		S	O	S	O		O							
DIL				S	O		O		O		O			O							
DIS				S	O		O		O		O			O							

S = In Stock O = Special Order

BASE



111
1/2 x 1-1/2

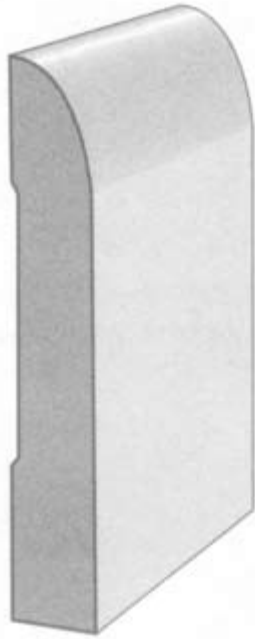

115
7/16 x 2-1/2

123
3/8 x 2-1/4

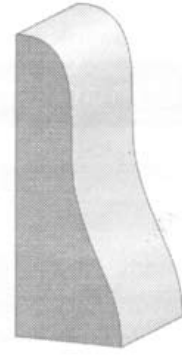

107
5/8 x 1-5/8

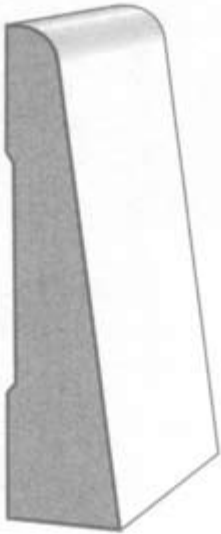

116
1/2 x 2-1/2

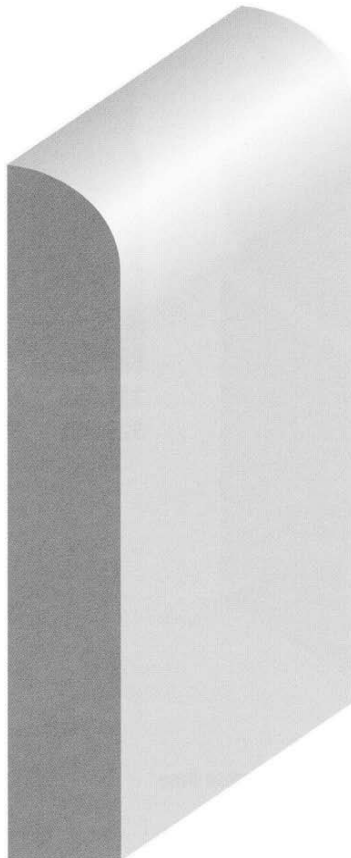

127
3/16 X 3-1/2

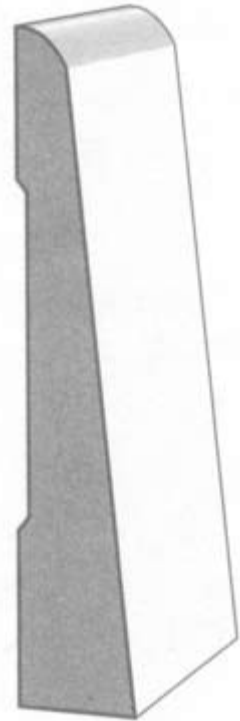

118
1/2 x 3-1/2

** SEE MOULDING INFORMATION PAGE FOR AVAILABILITY **

BASE

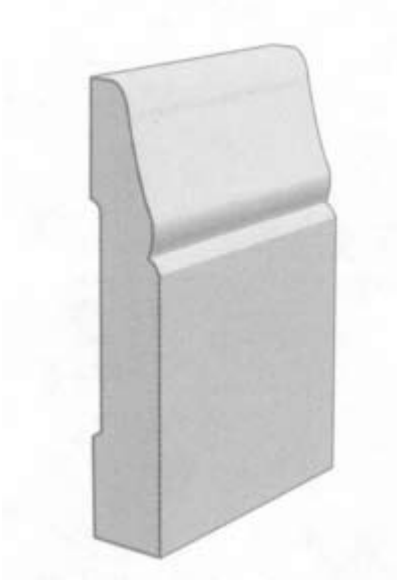

132
1/2 x 2-1/2 711

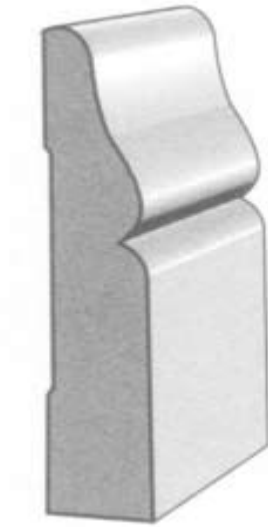

133
5/8 x 2-1/2 711

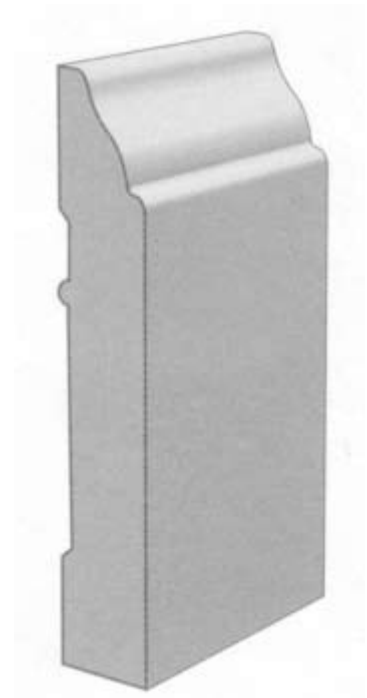

153
9/16 x 3-1/4

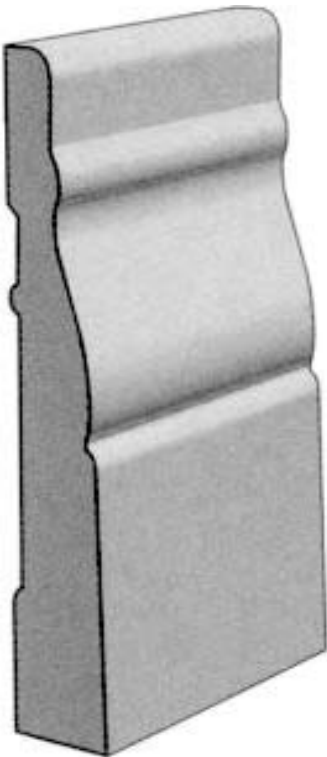

146
1/2 x 3-1/4

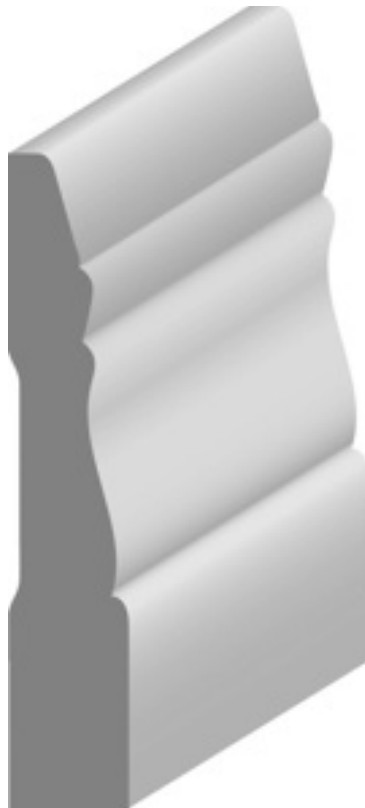

149
9/16 x 3-1/4



137
1/2 x 3-1/2 711

** SEE MOULDING INFORMATION PAGE FOR AVAILABILITY **

BASE

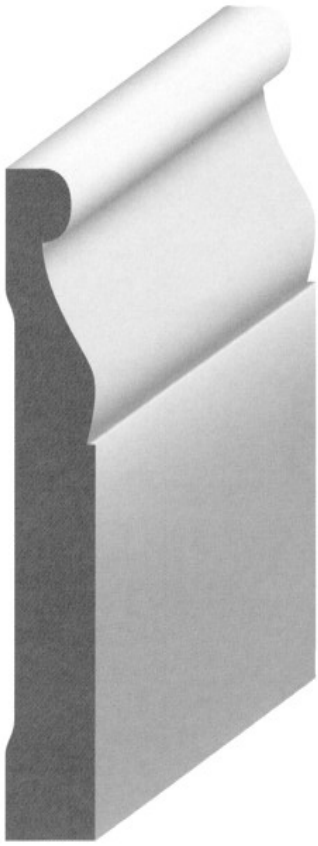

180
1/2 x 3-1/2



189
9/16 x 3-1/2

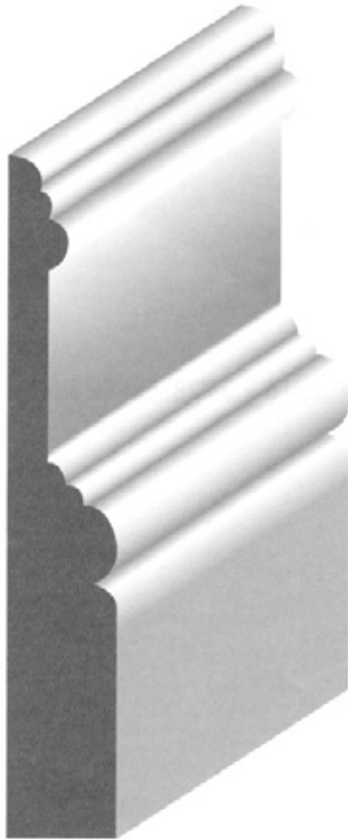

165
9/16 x 3-1/2

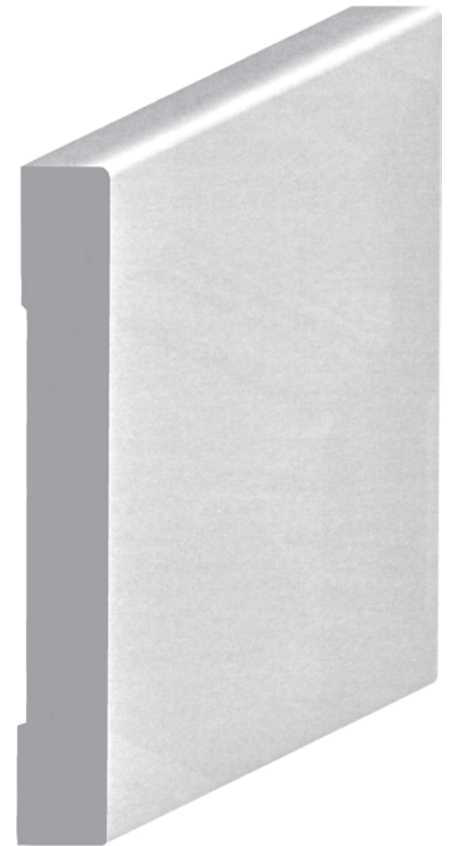

864
1/2 x 3-1/2

** SEE MOULDING INFORMATION PAGE FOR AVAILABILITY **

BASE

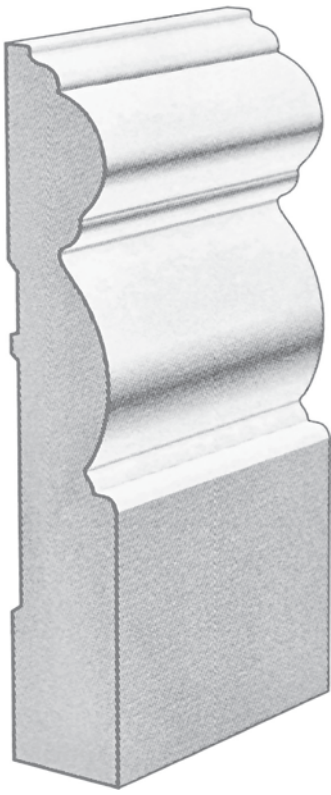

160
9/16 x 3-3/4



210
7/16 x 3-7/8

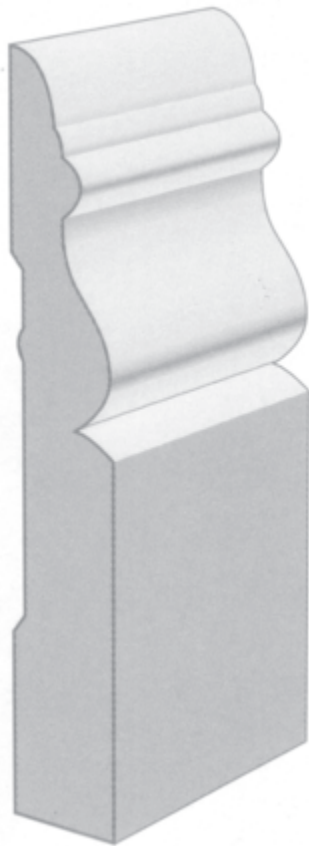

200
9/16 x 3-7/8



170
9/16 x 3-1/2

** SEE MOULDING INFORMATION PAGE FOR AVAILABILITY **

BASE

Corners for Bullnose Drywall are available for all Baseboards.

Flexible Baseboards are also available in 6' and 12' lengths.

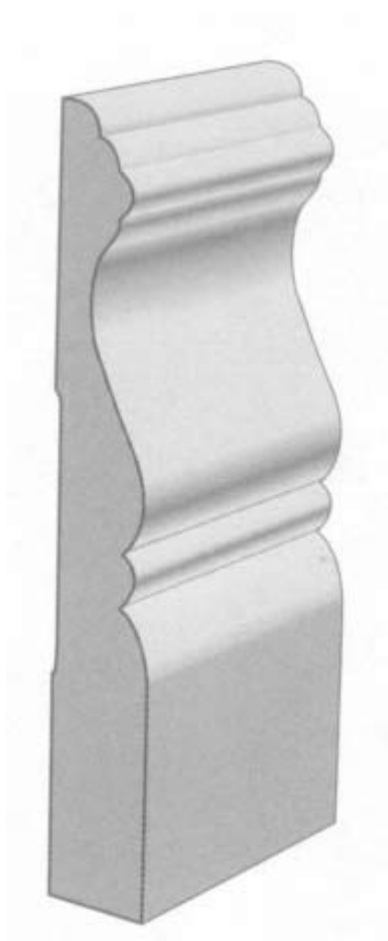

212
9/16 x 4

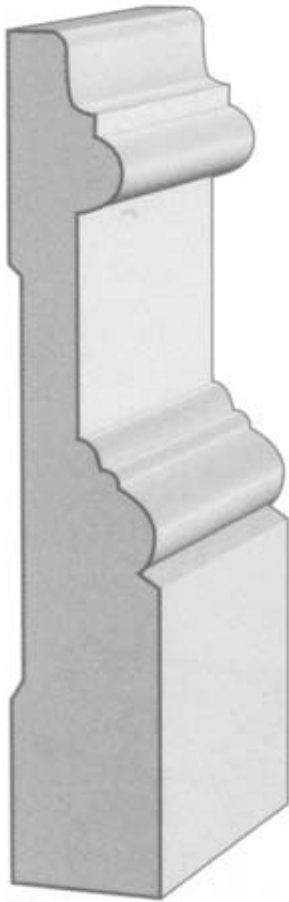

167
5/8 x 4-1/4

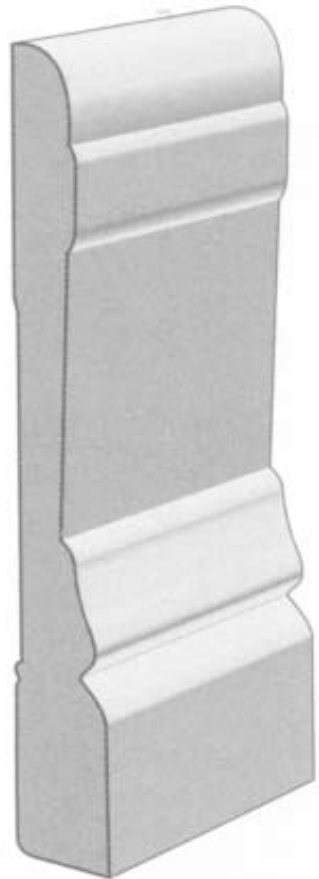

173
5/8 x 4-1/4

171
9/16 x 4-1/4

** SEE MOULDING INFORMATION PAGE FOR AVAILABILITY **

BASE



154
9/16 x 4-1/4

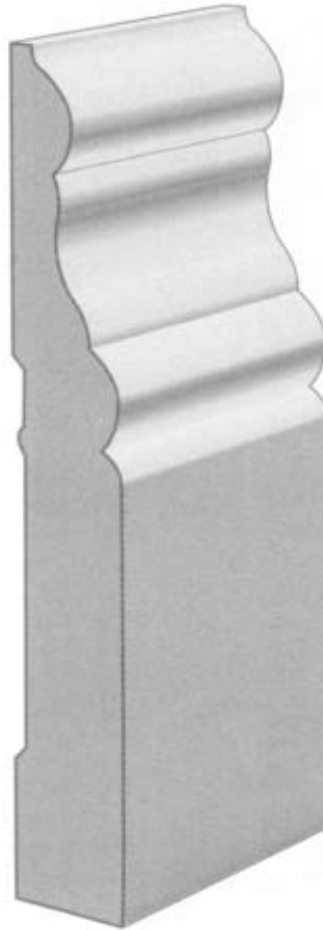

220
9/16 x 4-1/2

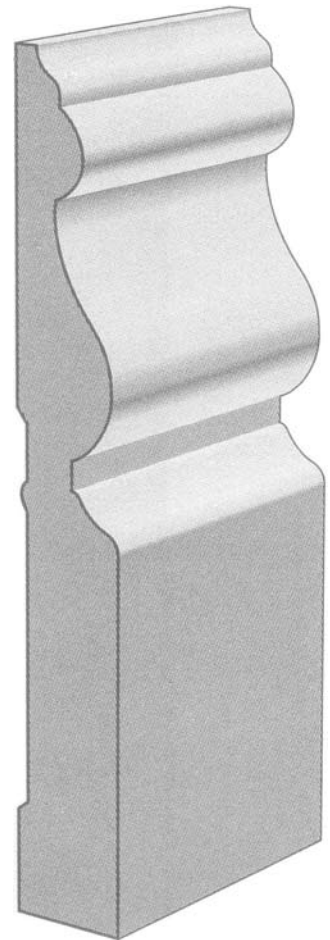

193
9/16 x 4-1/2

** SEE MOULDING INFORMATION PAGE FOR AVAILABILITY **

BASE



161
9/16 x 5

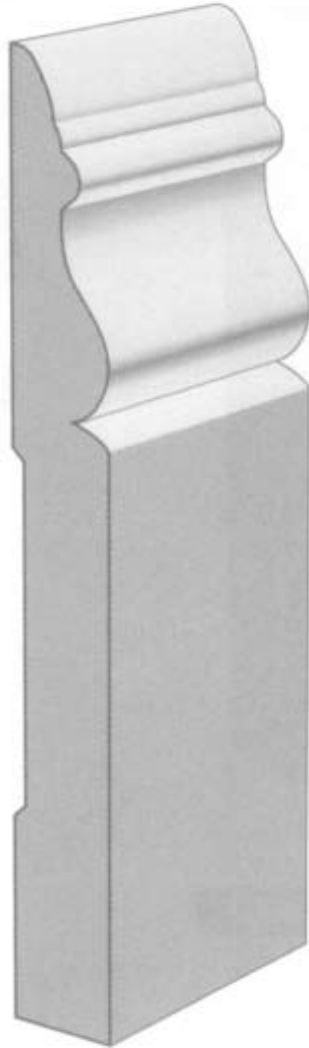

202
9/16 x 5

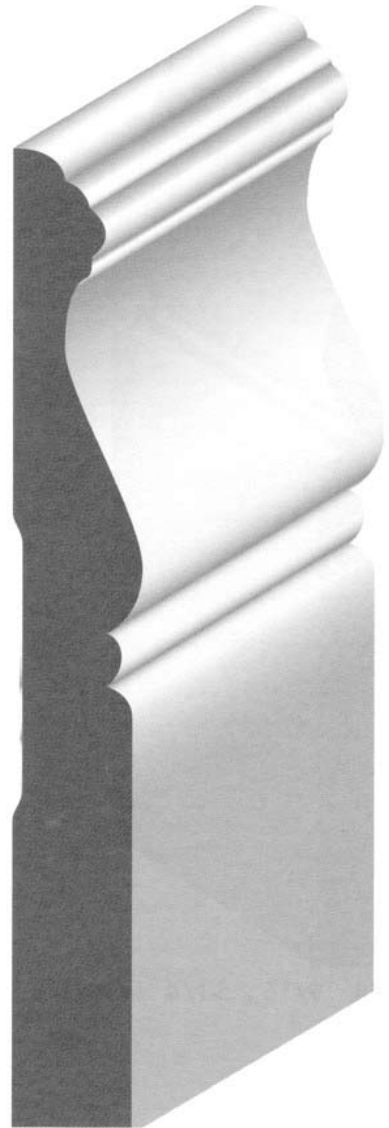

214
9/16 x 5-1/4

** SEE MOULDING INFORMATION PAGE FOR AVAILABILITY **

*All images are approximate

BASE

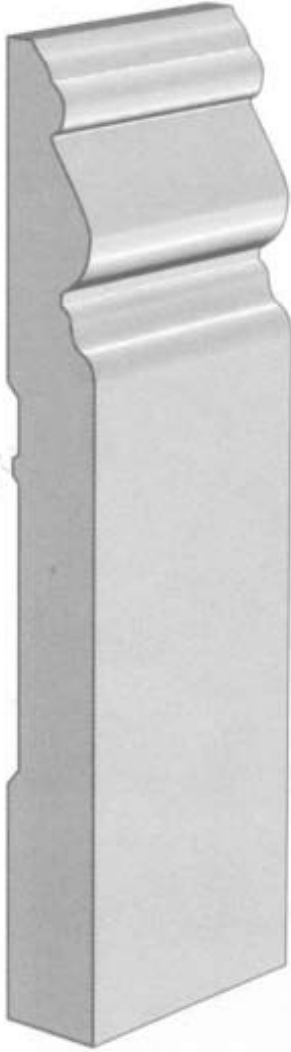

194
9/16 x 5-1/4



155
9/16 x 5-1/4

** SEE MOULDING INFORMATION PAGE FOR AVAILABILITY **

BASE



184
9/16 x 5-1/4

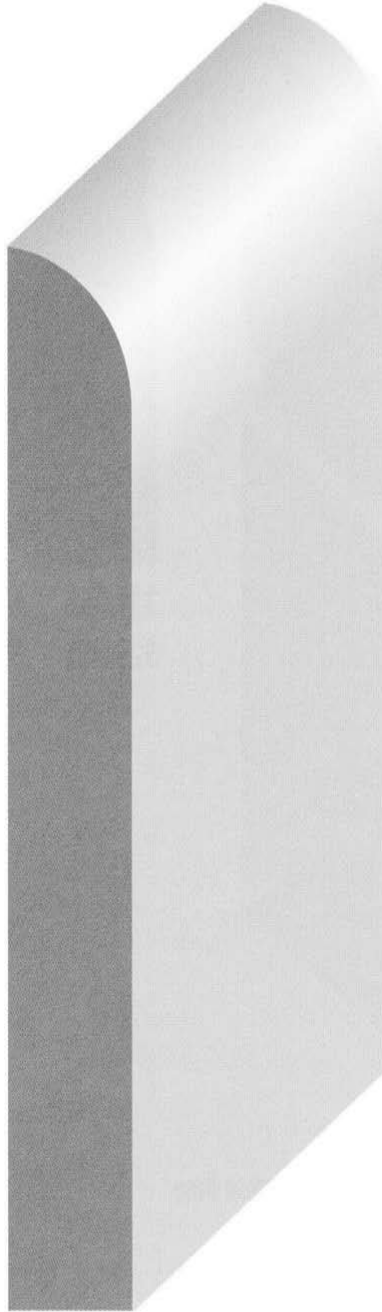

128
9/16 x 5-1/2



196
9/16 x 6

** SEE MOULDING INFORMATION PAGE FOR AVAILABILITY **

BASE

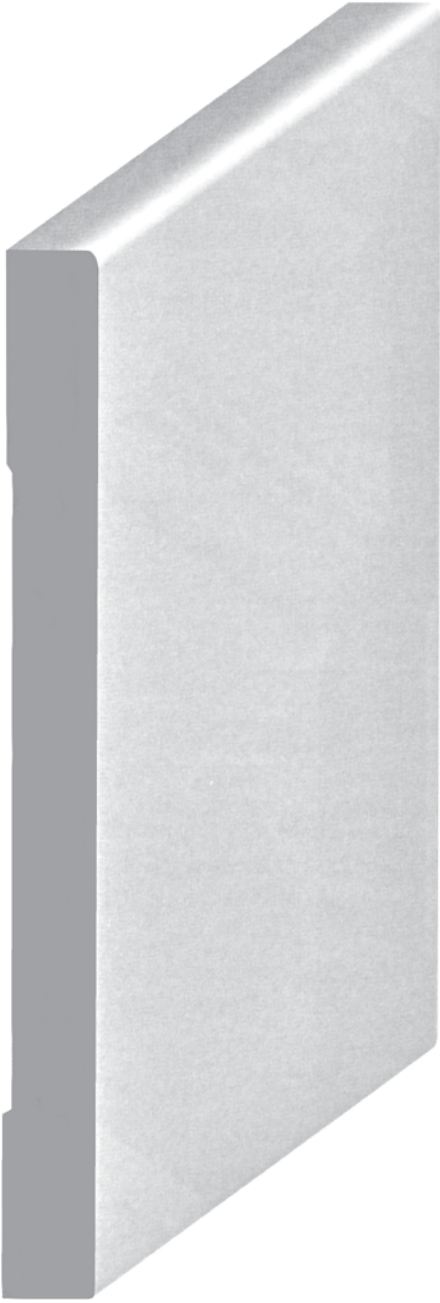

865
1/2 x 5-1/2

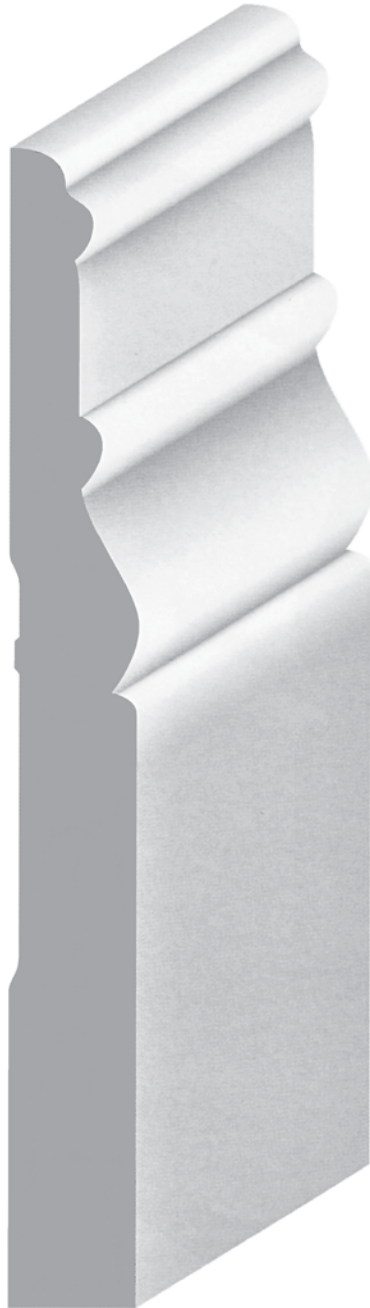

255
11/16 x 6

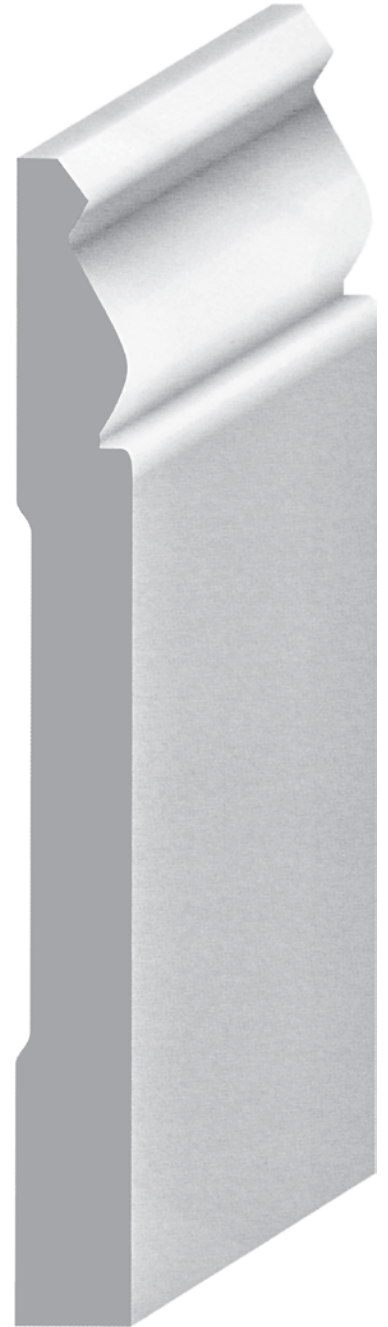

185
9/16 x 6-1/8

** SEE MOULDING INFORMATION PAGE FOR AVAILABILITY **

BASE



162
9/16 x 7-1/4

** SEE MOULDING INFORMATION PAGE FOR AVAILABILITY **

CASING

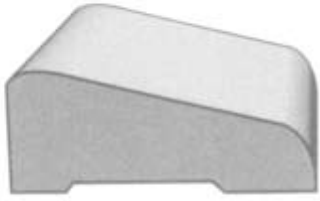

302
9/16 x 1-9/16

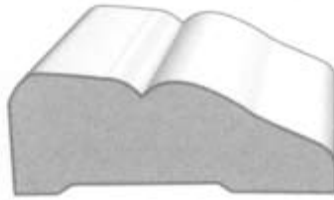

322
5/8 x 1-5/8

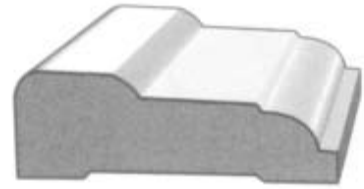

350
1/2 x 1-5/8

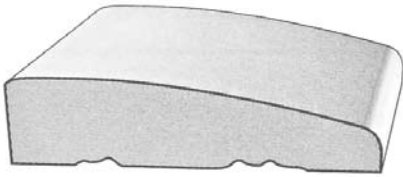

315
9/16 x 2

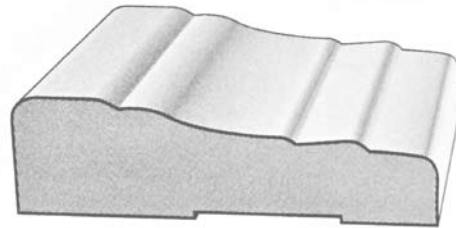

345
5/8 x 2-1/4

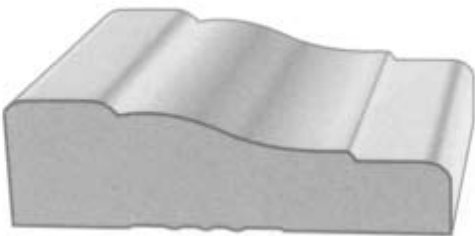

340
9/16 x 2

341
9/16 x 2-1/4

343
11/16 x 3-1/4



324
9/16 x 2-1/2 or
5/8 x 2-1/2 Depending on Species



360
5/8 x 2-1/2

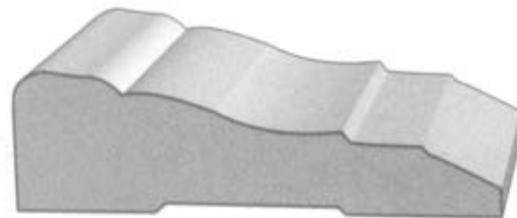

346
11/16 x 2-1/2

** SEE MOULDING INFORMATION PAGE FOR AVAILABILITY **

CASING

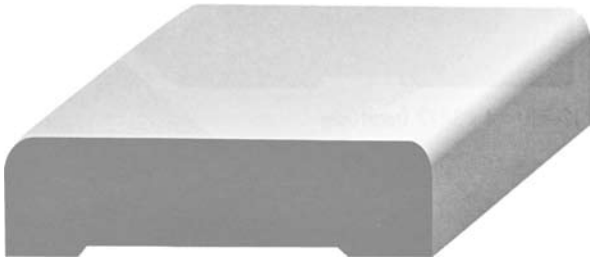

331
9/16 x 2-1/4

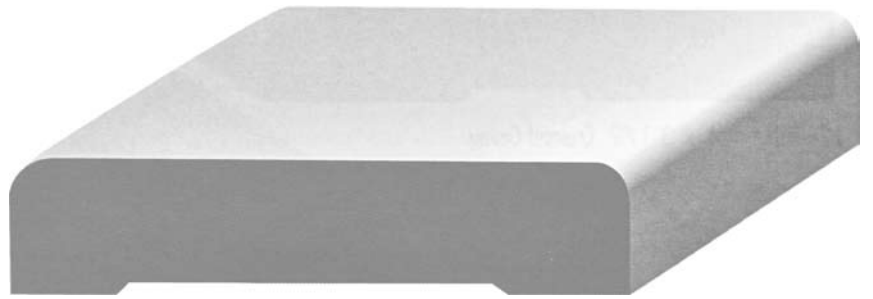

333
11/16 x 3-1/4

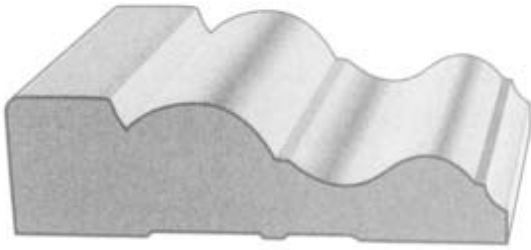

415
11/16 x 2-1/2

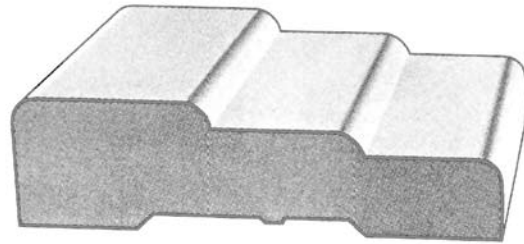

327
5/8 x 2-1/2

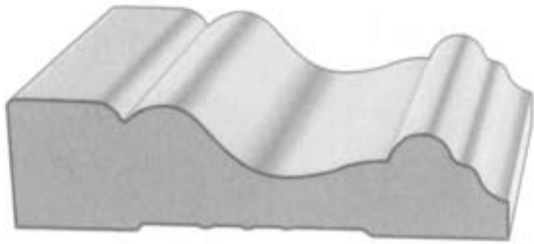

410
5/8 x 2-1/2

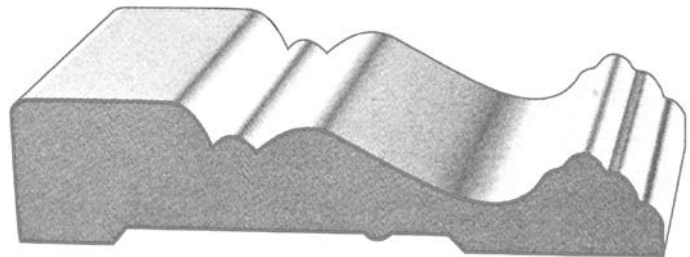

422
11/16 x 3-1/2

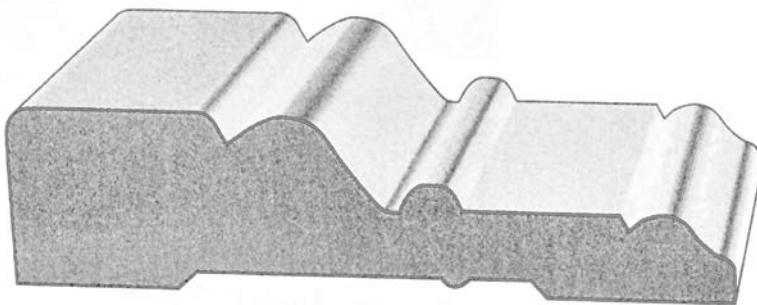

470
7/8 x 3-3/4

** SEE MOULDING INFORMATION PAGE FOR AVAILABILITY **

*All images are approximate

CASING

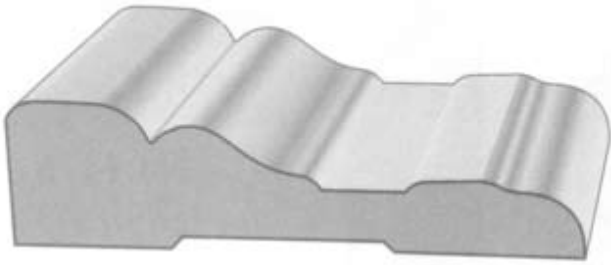

365
11/16 x 2/7/8

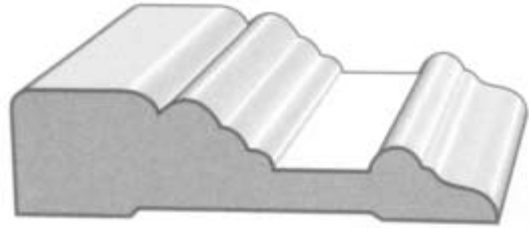

370
11/16 x 2-1/2

371
3/4 X 2-5/8

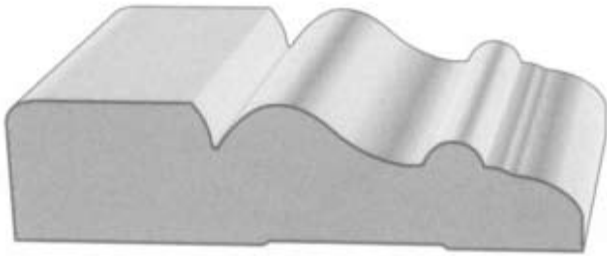

400
11/16 x 2-7/8

401
5/8 x 2-1/2

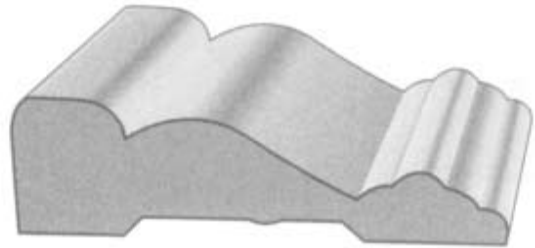

420
11/16 x 2-1/2

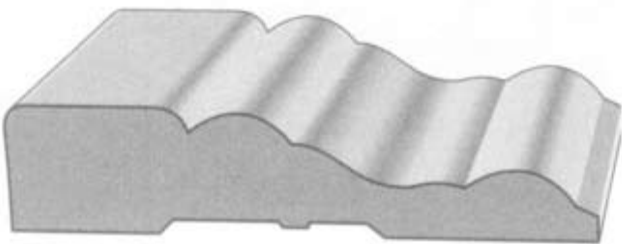

450
5/8 x 3

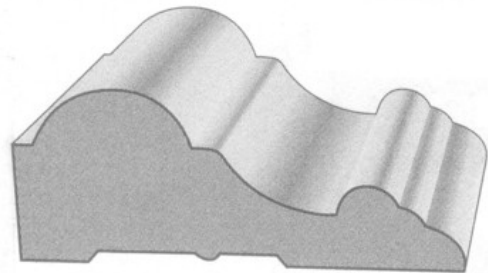

380
1 x 2-1/2

** SEE MOULDING INFORMATION PAGE FOR AVAILABILITY **

CASING

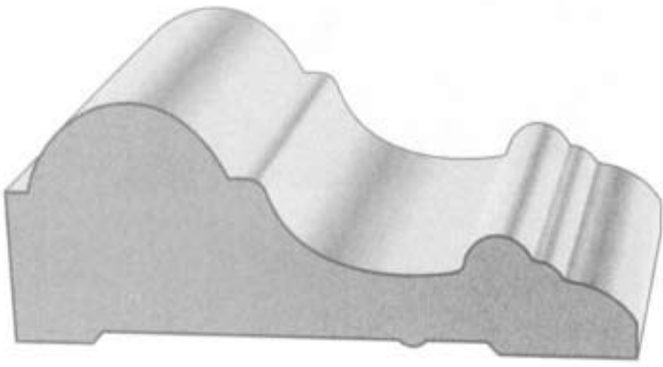

381
1-3/16 x 3-3/16

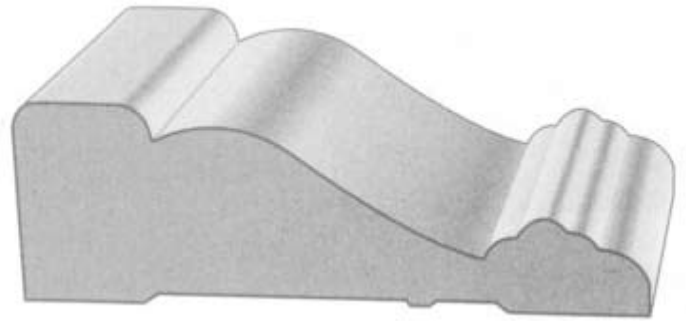

421
1 x 3-1/4

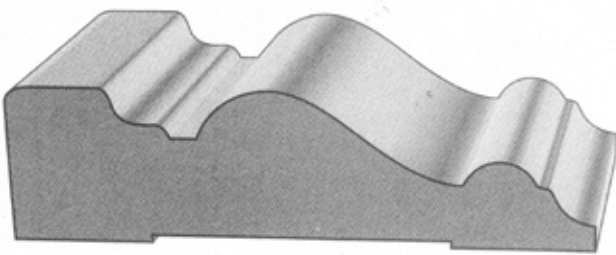

356
11/16 x 3

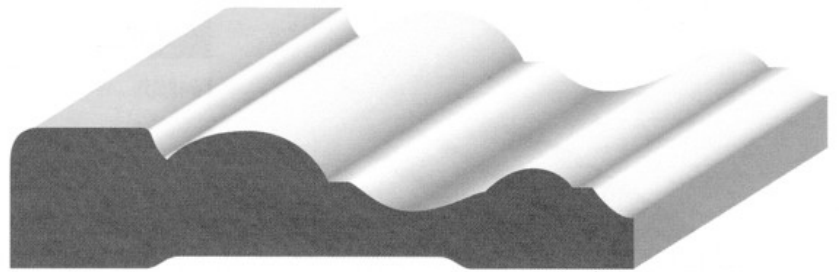

417
11/16 x 3-1/4

374
1 x 3-1/2

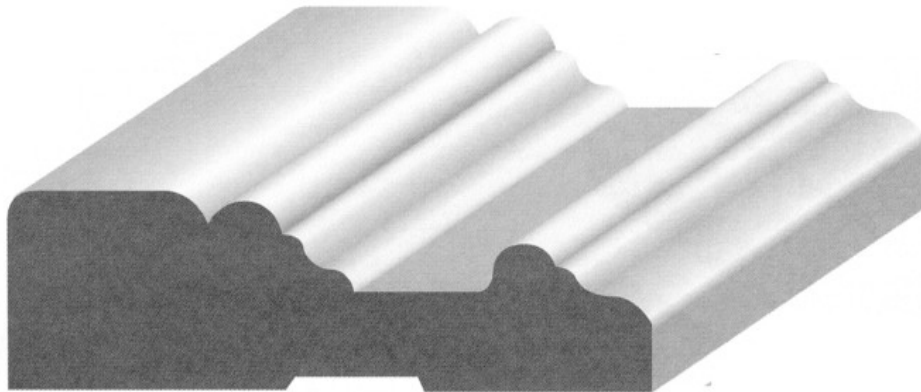

447
1-1/16 x 3-1/2

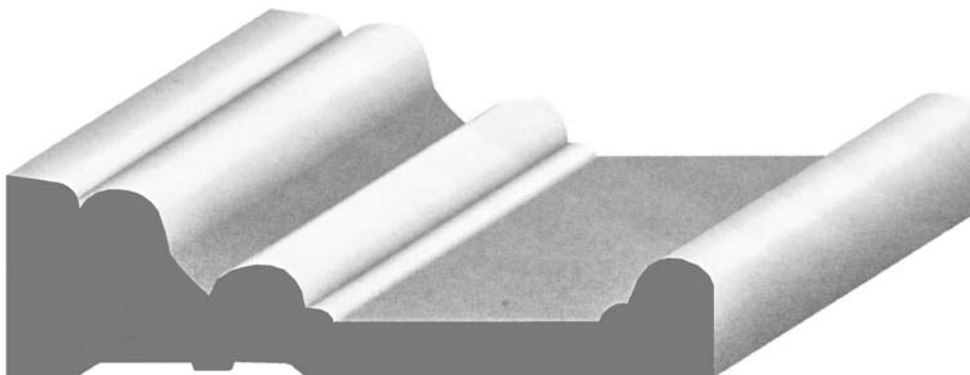

** SEE MOULDING INFORMATION PAGE FOR AVAILABILITY **

CASING

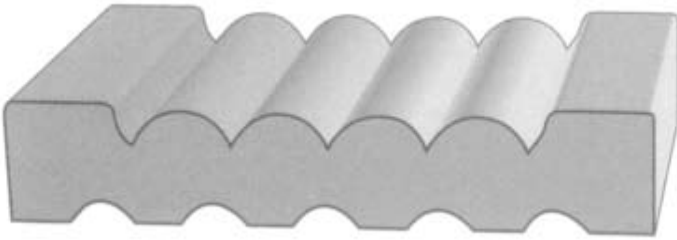

495
9/16 x 3-3/8

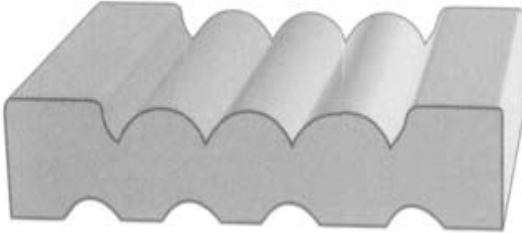

493
9/16 x 2-1/4

494
11/16 x 2-1/2

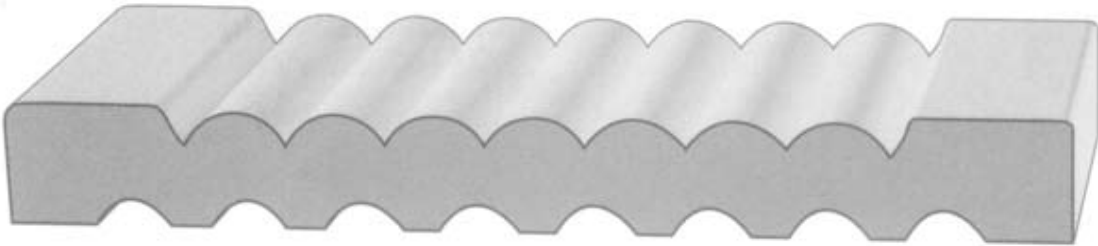

498
9/16 X 5-1/2

** SEE MOULDING INFORMATION PAGE FOR AVAILABILITY **

CROWN

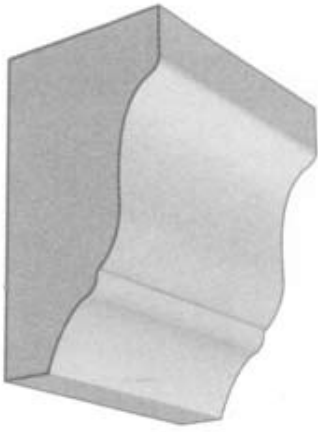

509
1 x 1-7/8

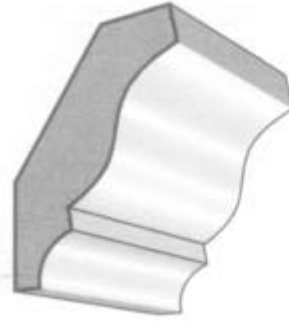
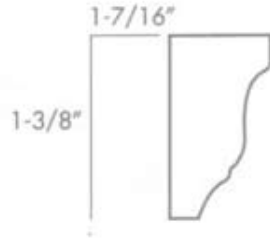

510
1-5/8

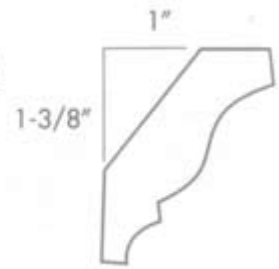

511
2-1/4

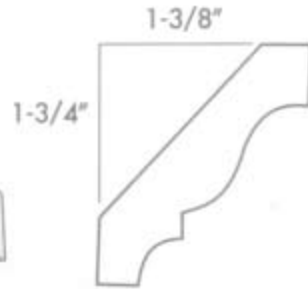

** SEE MOULDING INFORMATION PAGE FOR AVAILABILITY **

CROWN

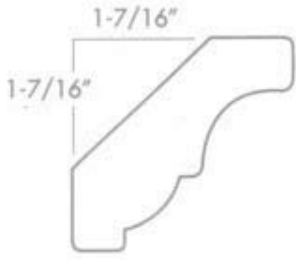

530
1-7/8

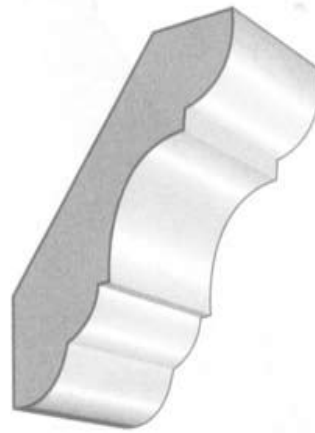

531 (MDF)
2-5/16

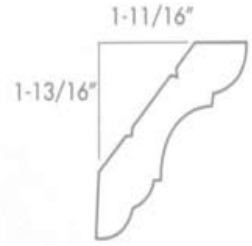

532 (Hardwood)
2-1/2

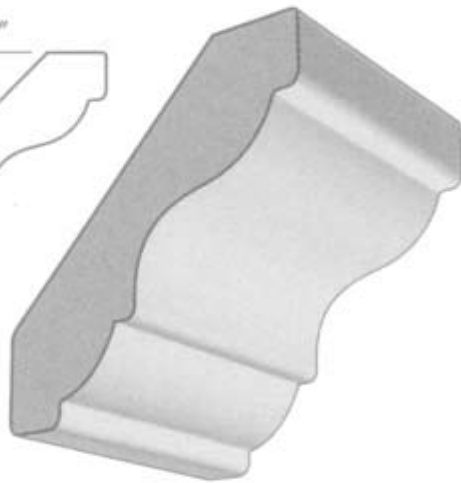
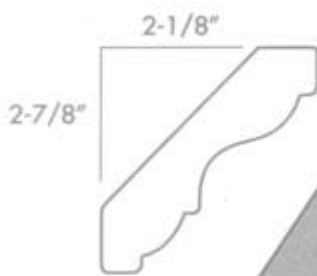

532 (MDF)
2-1/2

** SEE MOULDING INFORMATION PAGE FOR AVAILABILITY **

CROWN

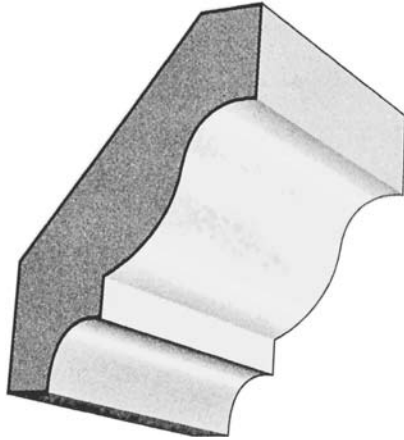
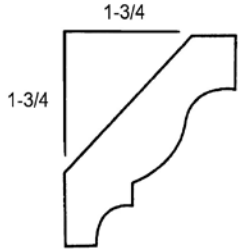

525
2-1/2

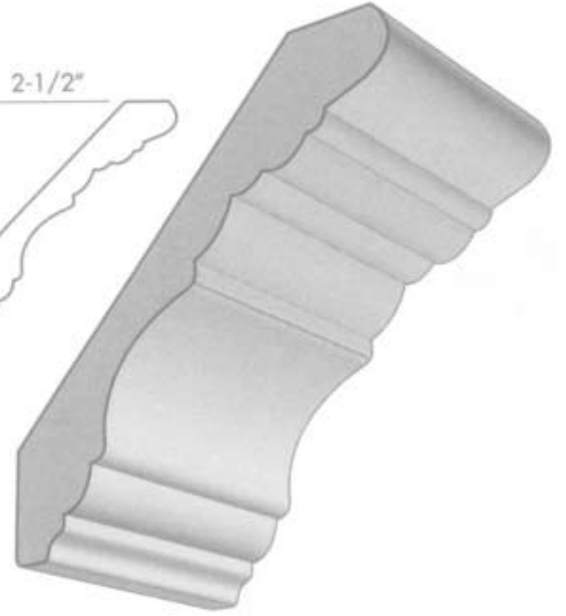
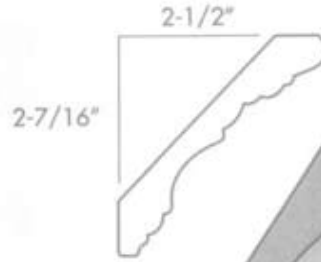

539
3-7/16

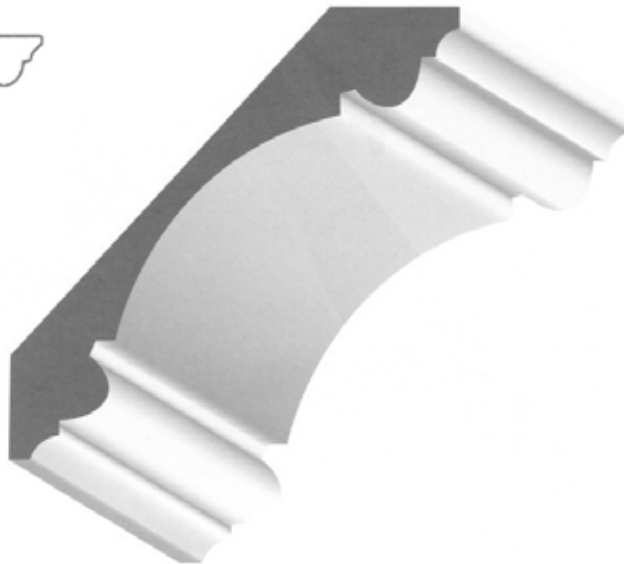
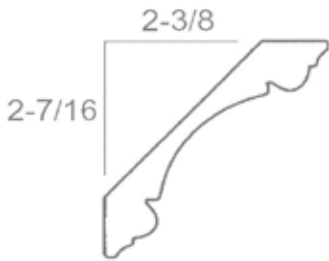

570
3-3/8

** SEE MOULDING INFORMATION PAGE FOR AVAILABILITY **

CROWN

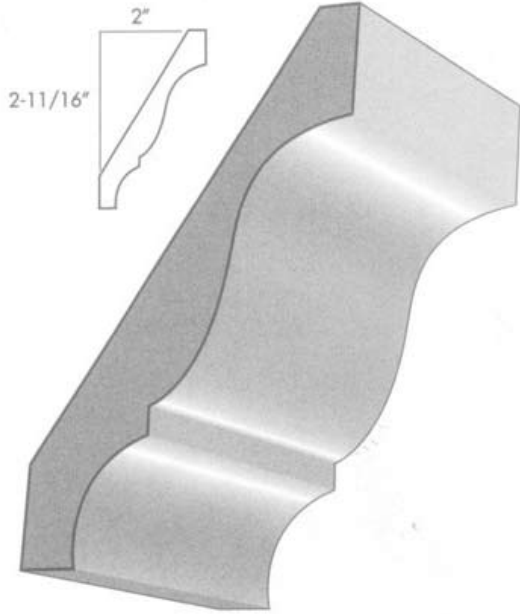

512
3-1/4

513
3-1/2

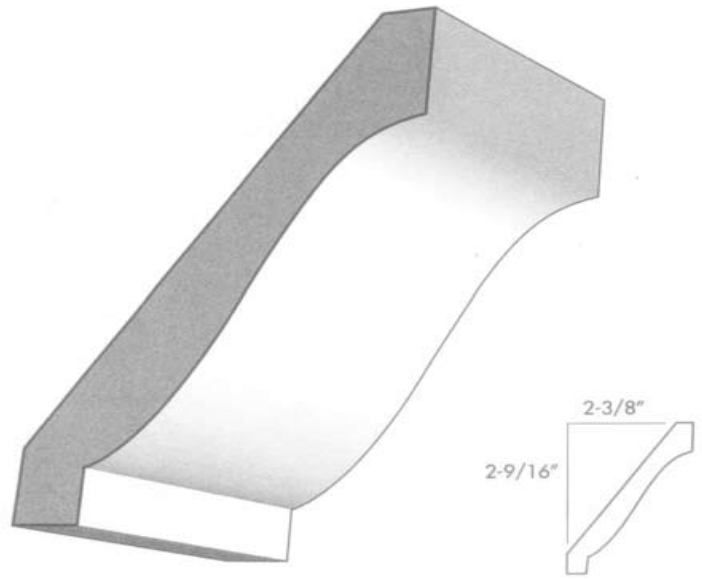

504
3-1/2

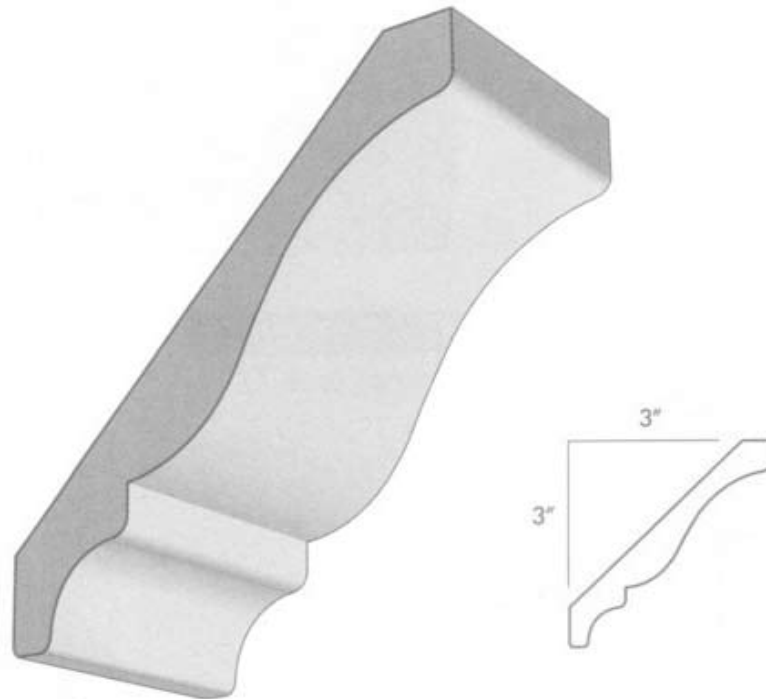

514
4-1/4

** SEE MOULDING INFORMATION PAGE FOR AVAILABILITY **

CROWN

INSERT READY CROWN
INSERT DENTIL OR
ROPE

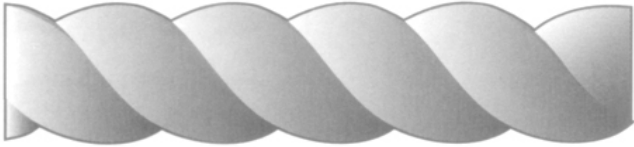

590
3-3/4"

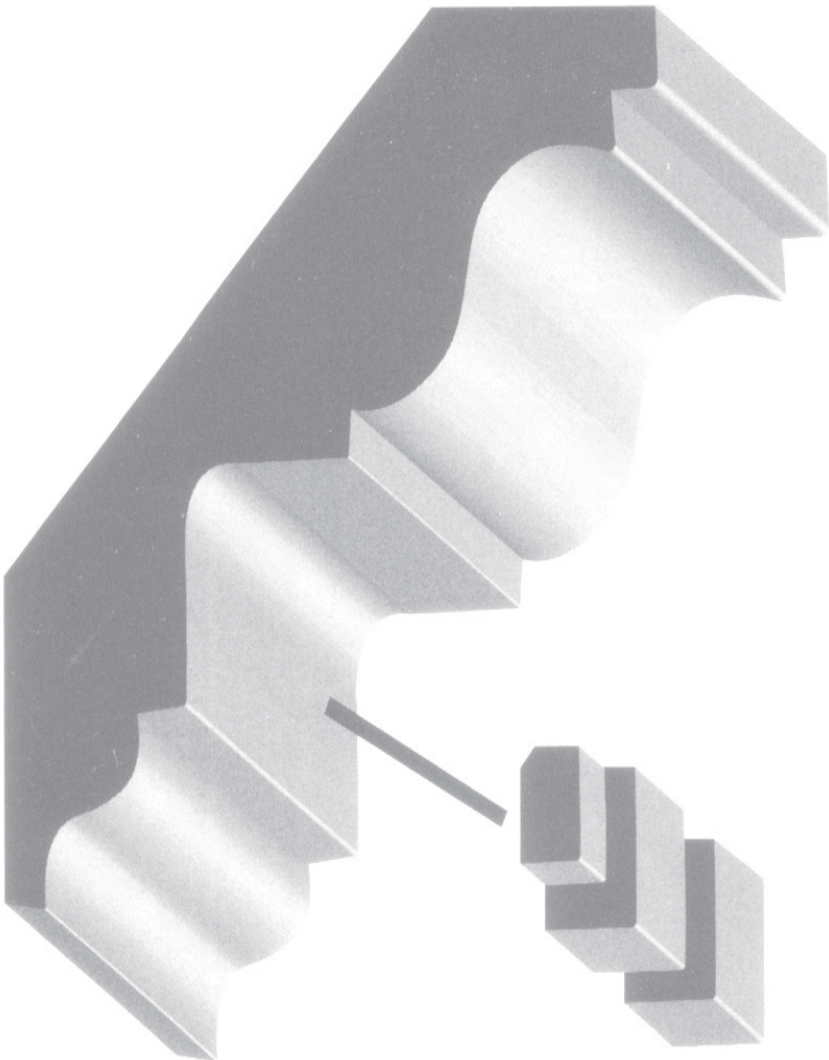
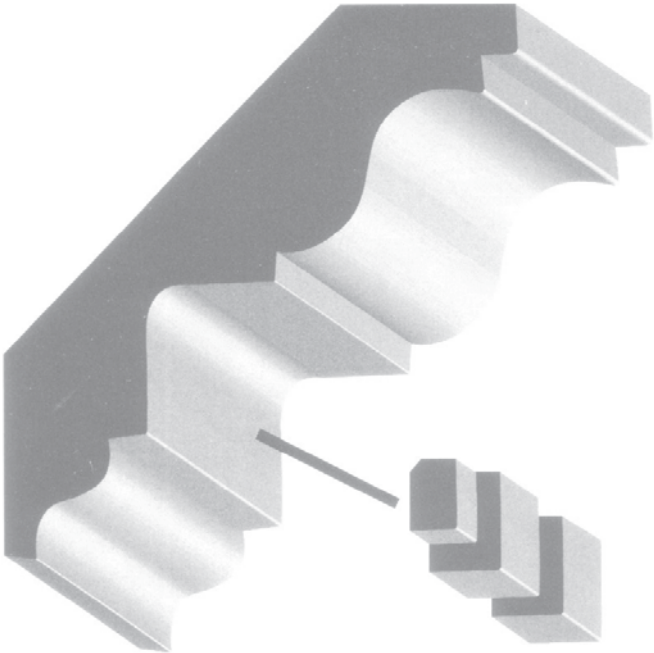

** SEE MOULDING INFORMATION PAGE FOR AVAILABILITY **

CROWN

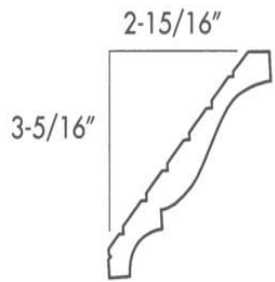
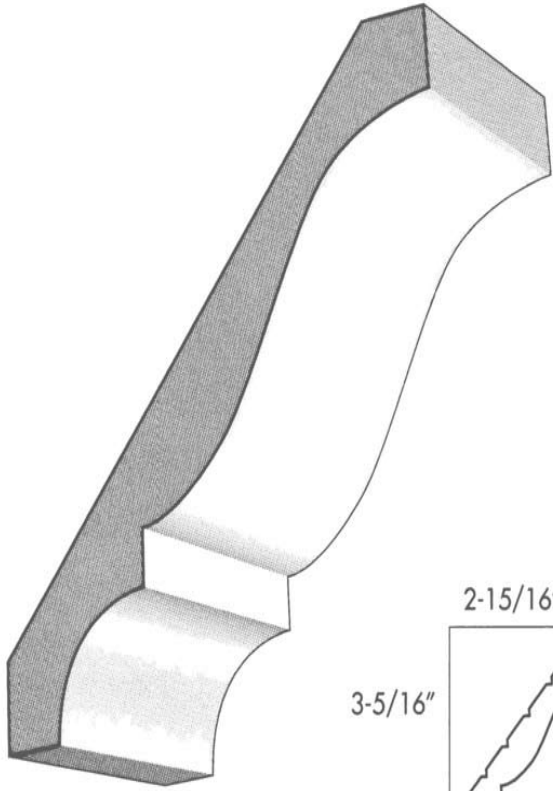

515
4-1/2

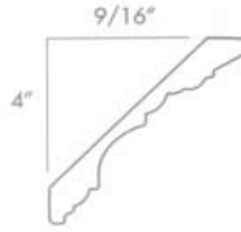

542
4-1/2

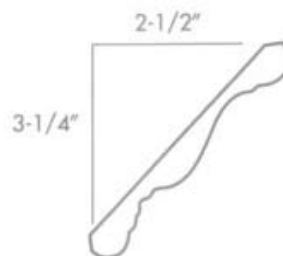
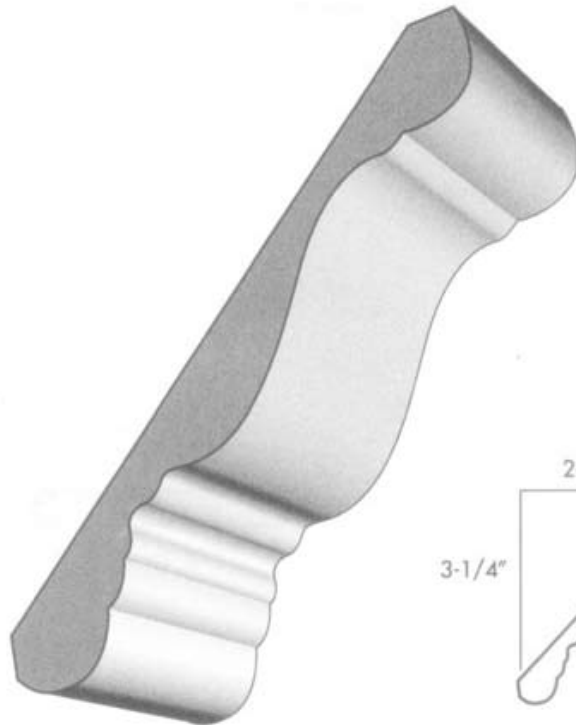

550
4-1/4

** SEE MOULDING INFORMATION PAGE FOR AVAILABILITY **

CROWN

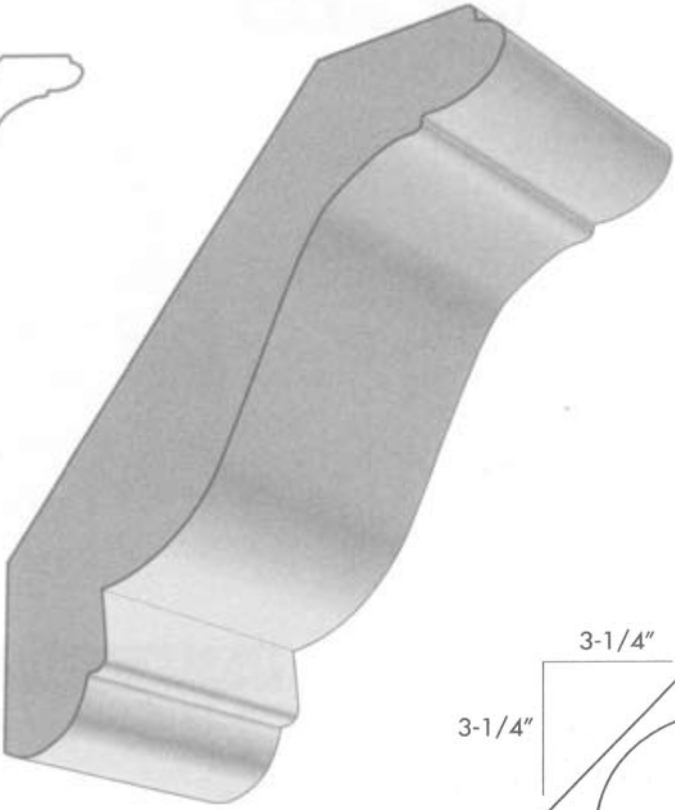
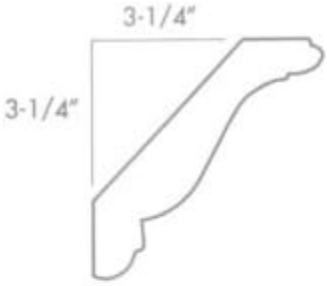

560
4-1/2

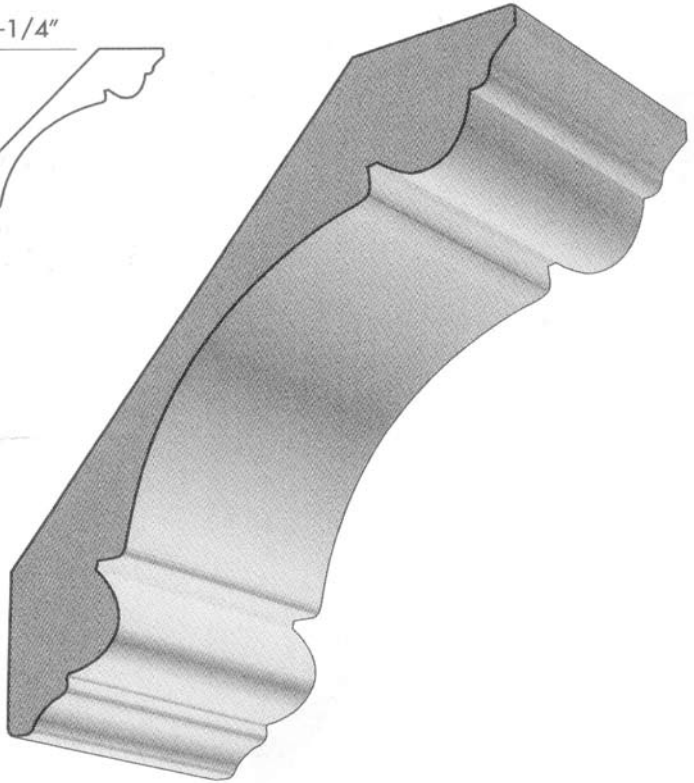
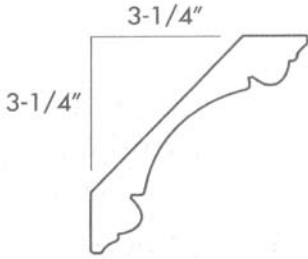

572
4-5/8

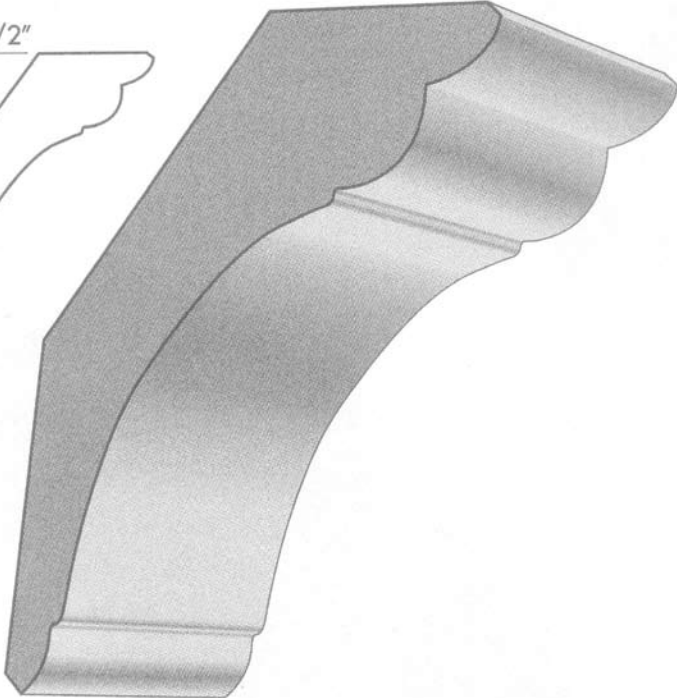
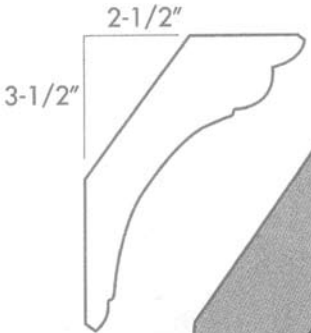

557
4-1/4

** SEE MOULDING INFORMATION PAGE FOR AVAILABILITY **

CROWN

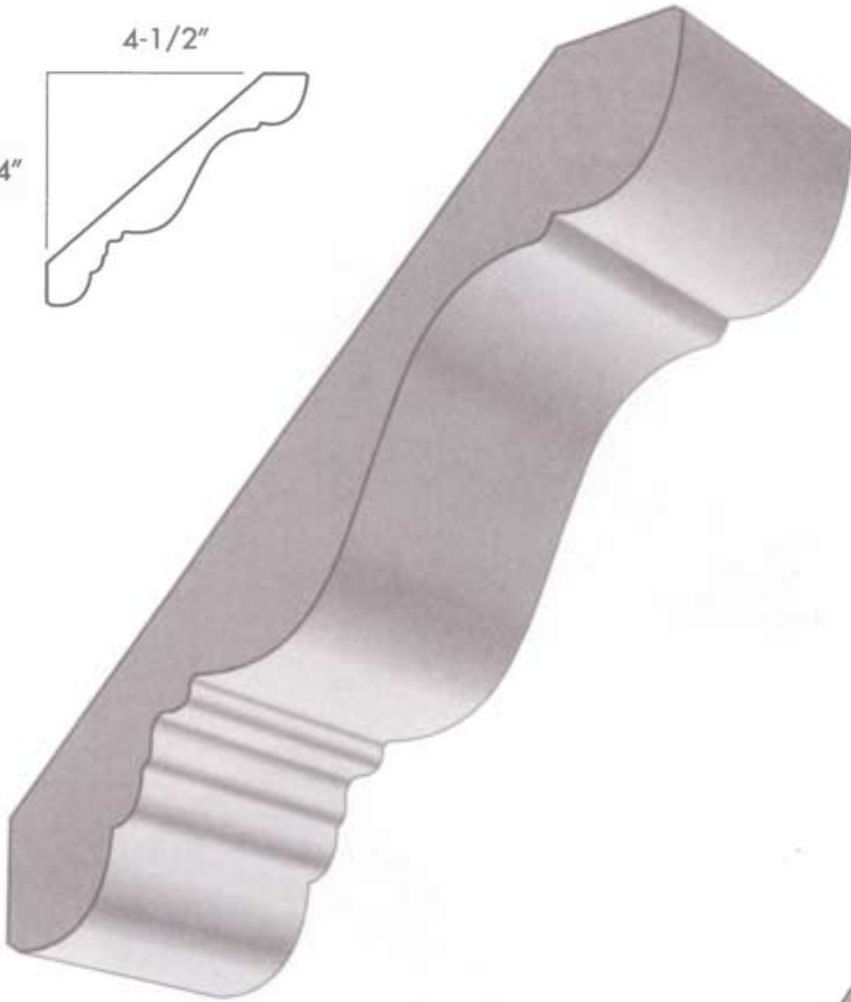
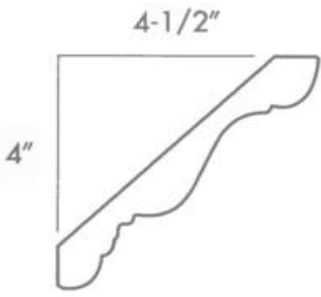

551
6

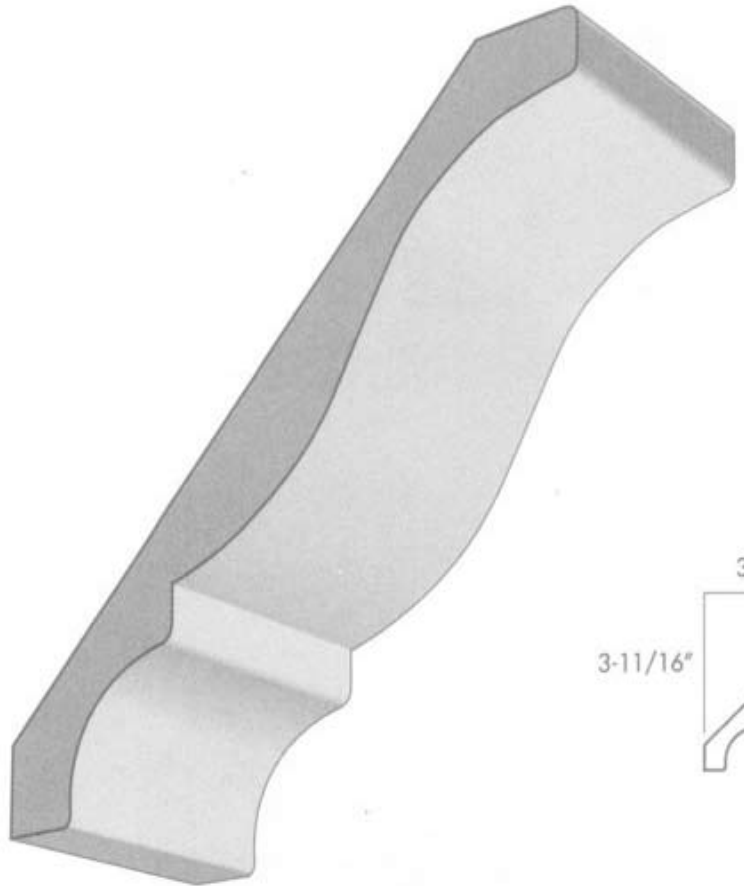
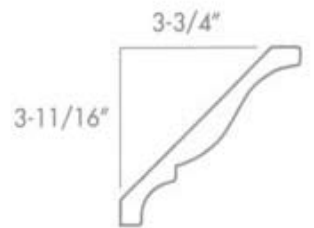

516
5-1/4

** SEE MOULDING INFORMATION PAGE FOR AVAILABILITY **

CROWN

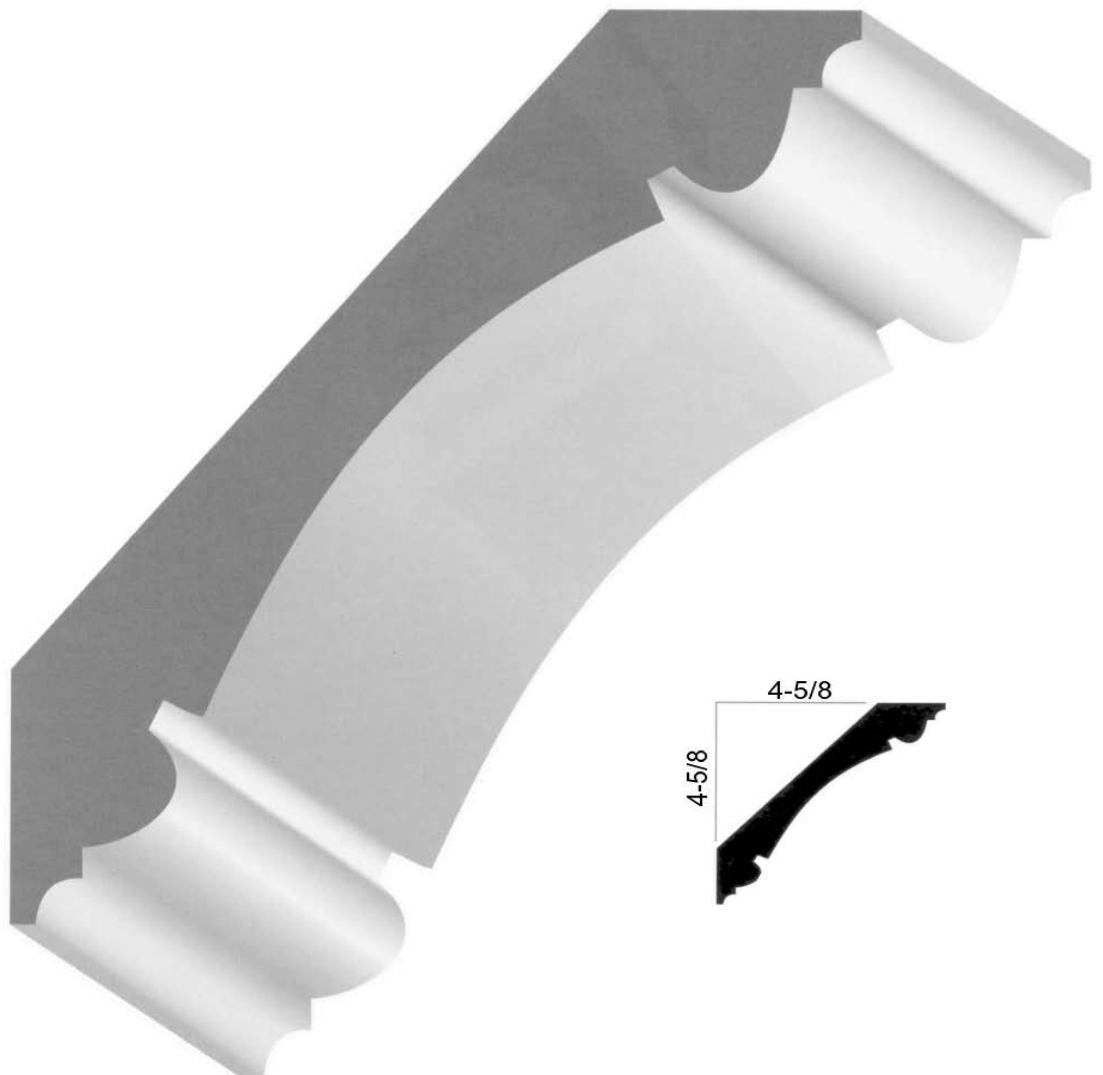
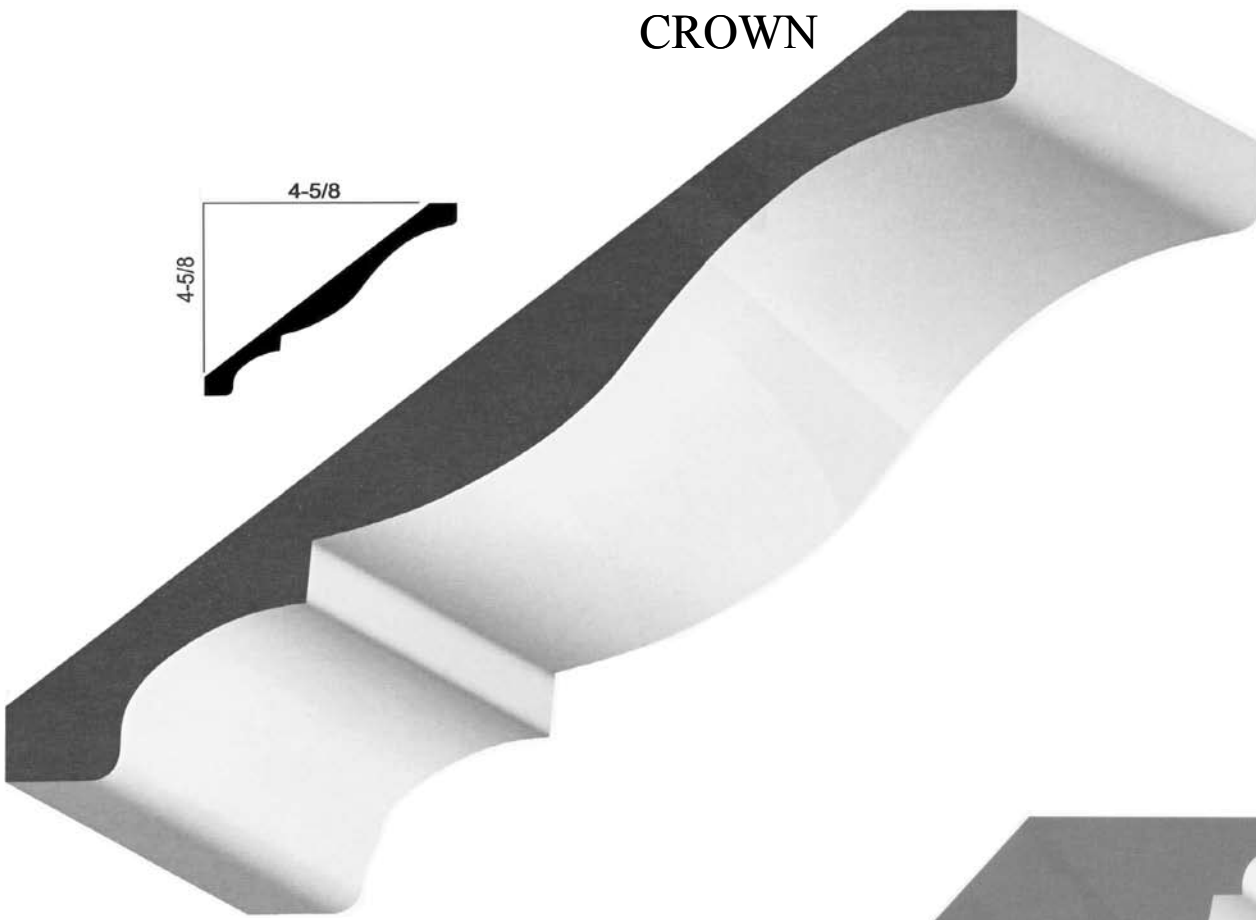

** SEE MOULDING INFORMATION PAGE FOR AVAILABILITY **

CROWN

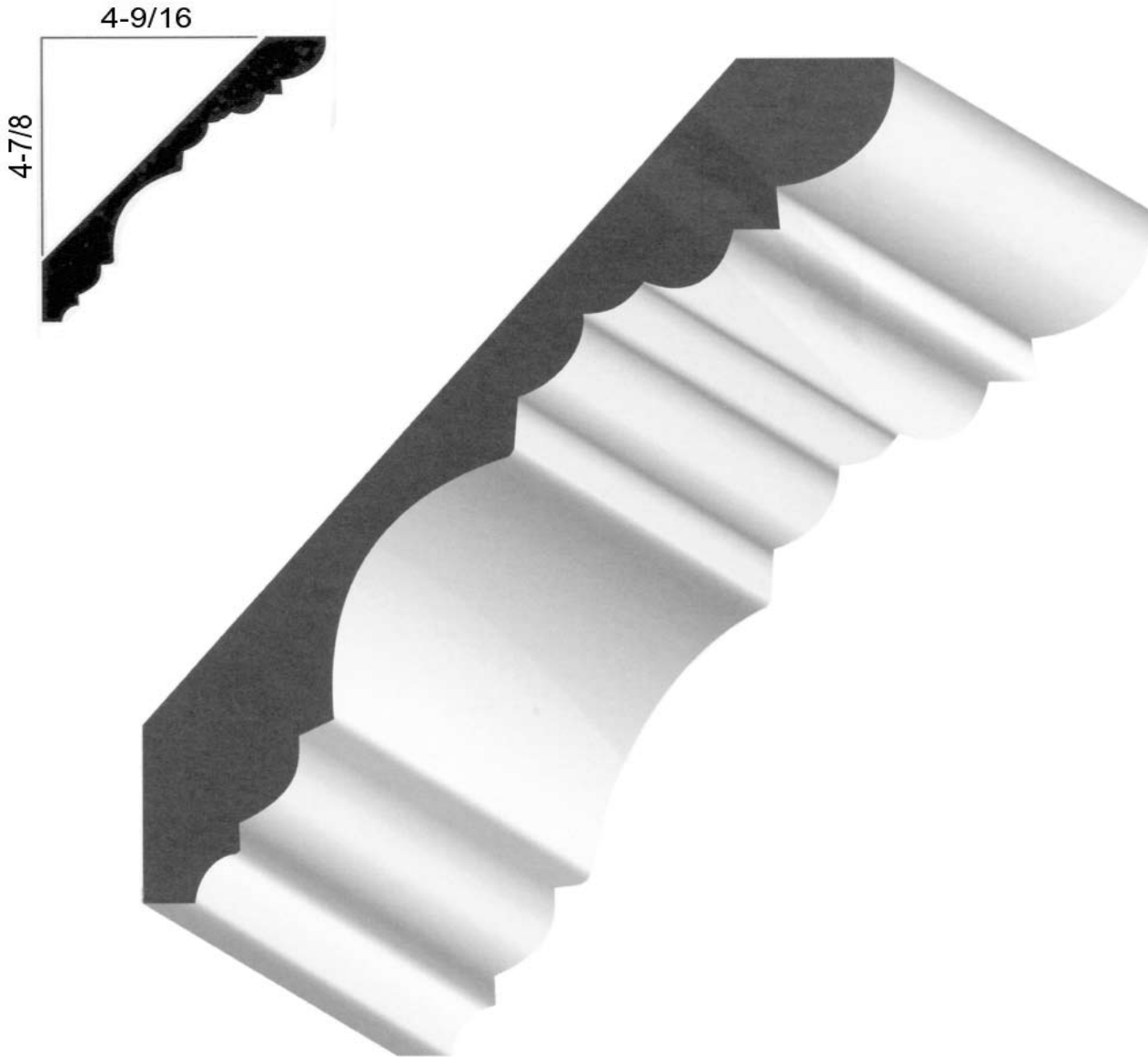

543
6-1/2

** SEE MOULDING INFORMATION PAGE FOR AVAILABILITY **

CROWN

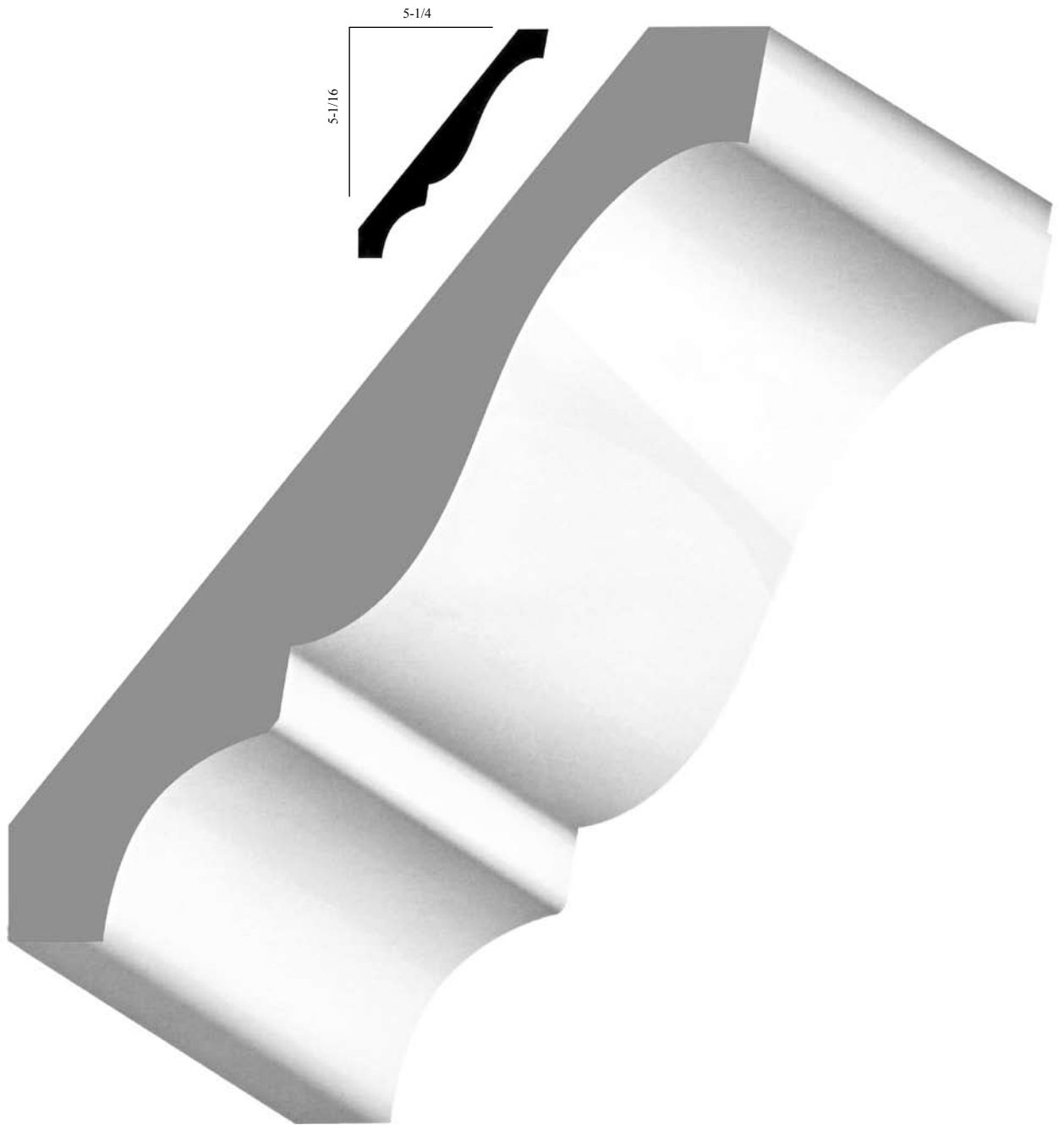

519
7-1/4

** SEE MOULDING INFORMATION PAGE FOR AVAILABILITY **

CROWN

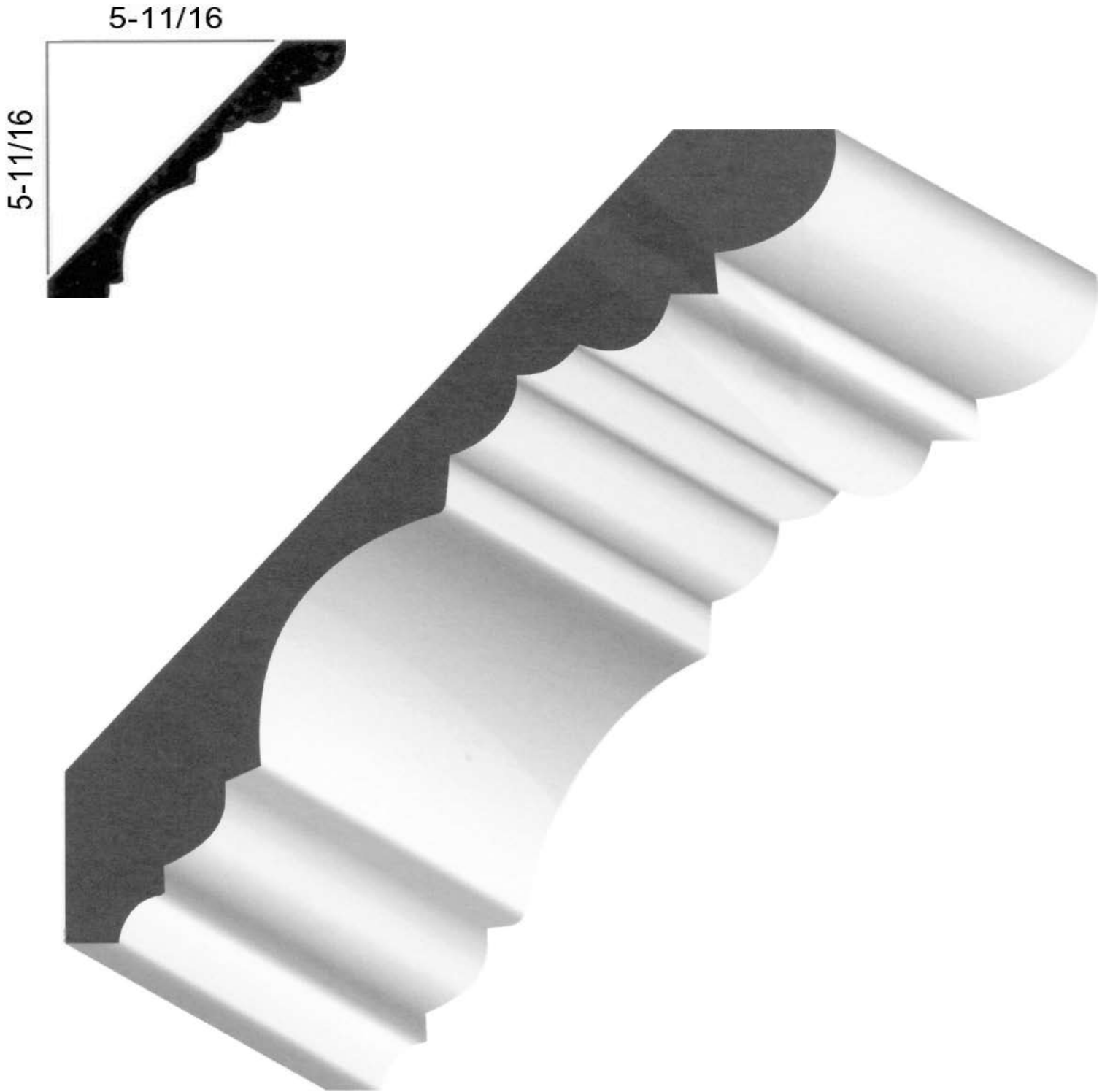

544
8"

** SEE MOULDING INFORMATION PAGE FOR AVAILABILITY **

CROWN

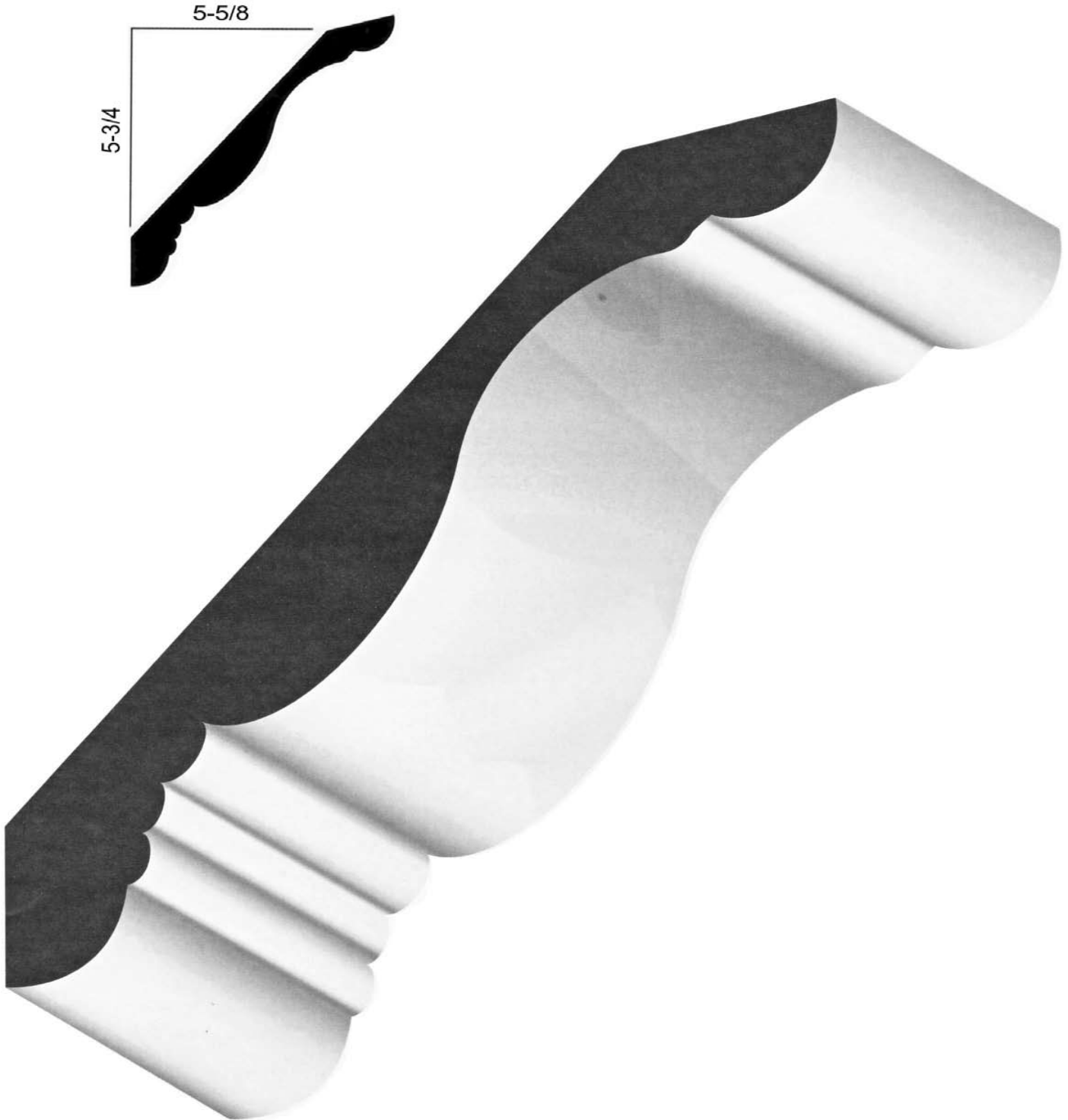

552
8"

** SEE MOULDING INFORMATION PAGE FOR AVAILABILITY **

Dentil

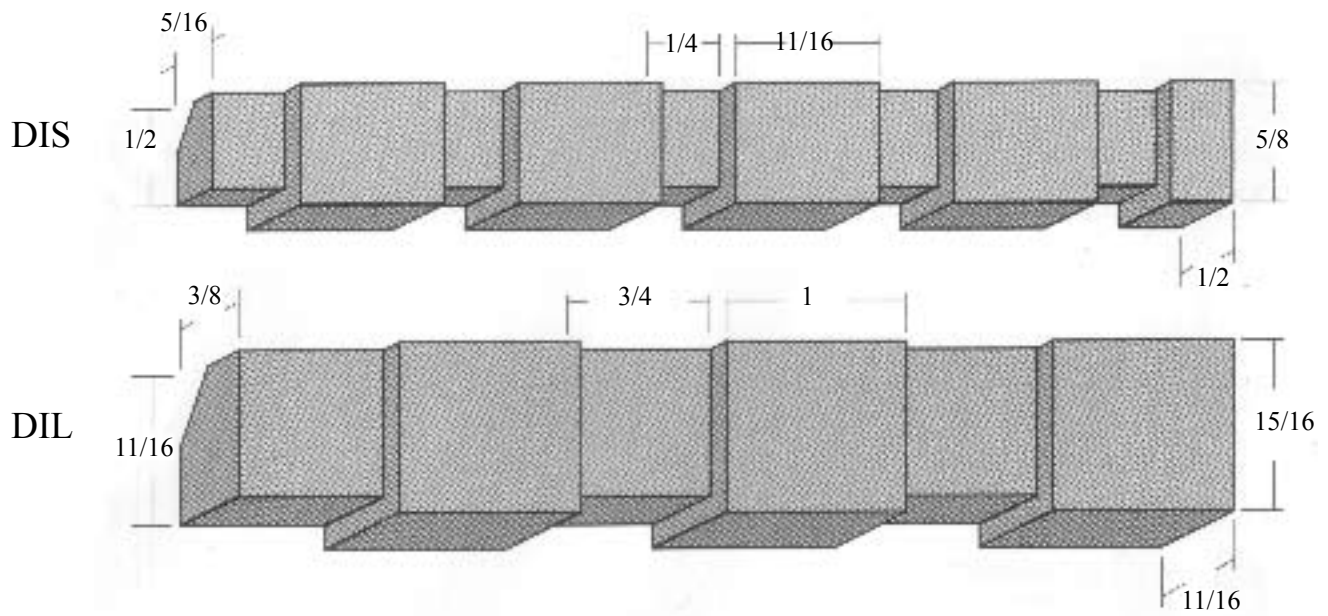

ROPE

RM38
3/16 x 3/8

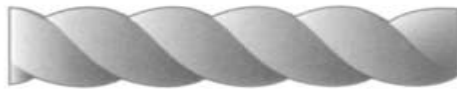

RM12
1/4 x 1/2

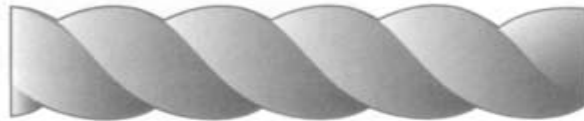

RM34
3/8 x 3/4

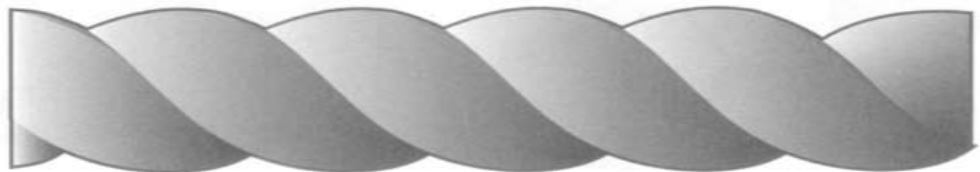

** SEE MOULDING INFORMATION PAGE FOR AVAILABILITY **

STOP



623
3/8 x 1-1/4
624 (MDF)



635
1/2 x 1-5/8



640
1/2 x 1-3/4

OVOLO STOP



3/8 x 9/16
or
3/8 x 11/16

FINGER JOINT JAMBS
4-9/16" 8/0 PR AND 17' LINEAL
4-1/8" 6'8" PR FJ EXT JAMB W/KERF IN STOCK.
OTHER SIZES AVAILABLE (SPECIAL ORDER)

COVE



651
1/2 x 1/2



654
3/4 x 3/4

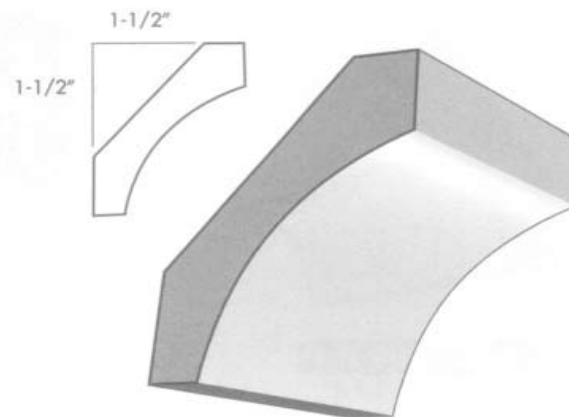

657
2-1/4

**** SEE MOULDING INFORMATION PAGE FOR AVAILABILITY ****

ROUNDS



670
1/4 x 1/4



671
3/8 x 3/8



672
1/2 x 1/2



675
3/4 x 3/4

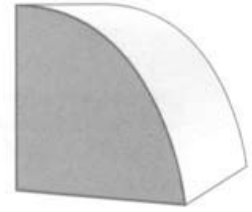

676
1 x 1



680
1/4 x 1/2



681
5/16 x 5/8



682
3/8 x 3/4



683
1/2 x 1



694
1-3/8



695
1-1/2



699
2

** SEE MOULDING INFORMATION PAGE FOR AVAILABILITY **

CORNER

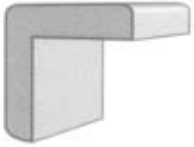

660
3/4 x 3/4

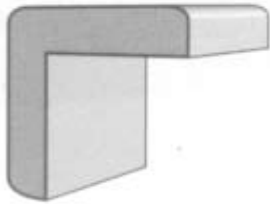

661
1 x 1

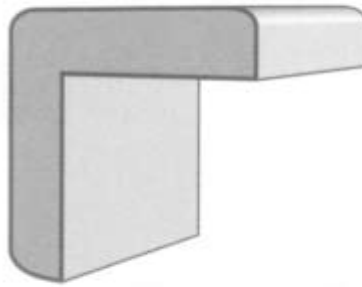

662
1-3/8 x 1-3/8

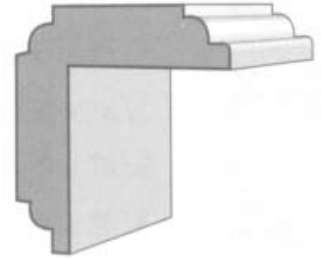

663
1-1/8 x 1-1/8
O* = 1-3/8 x 1-3/8

NOSE & COVE

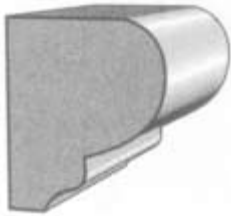

930
7/8 x 1



933
1-1/8 x 1-3/4

932
1 x 1-5/8

** SEE MOULDING INFORMATION PAGE FOR AVAILABILITY **

PANEL



700
1/2 x 3/4



702
3/8 x 1-3/8



720
3/8 x 5/8

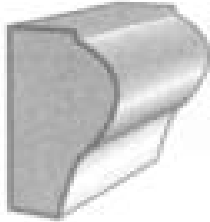

722
3/4 x 1



730
1/2 x 7/8



920
11/16 x 1-3/8

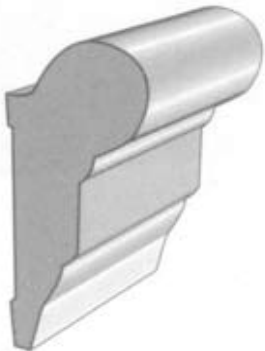

925
11/16 x 1-5/8



919
3/8 x 1-1/8

** SEE MOULDING INFORMATION PAGE FOR AVAILABILITY **

CHAIR RAIL



754
5/8 x 2-1/2

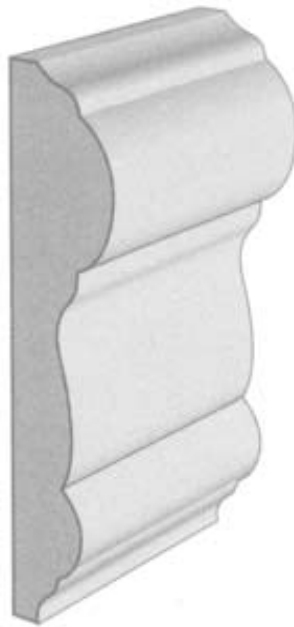

760
11/16 x 3

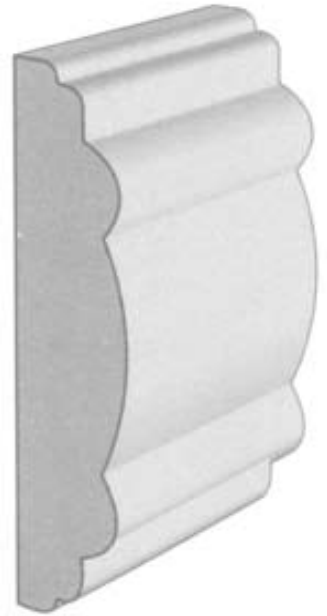

762
3/4 x 3

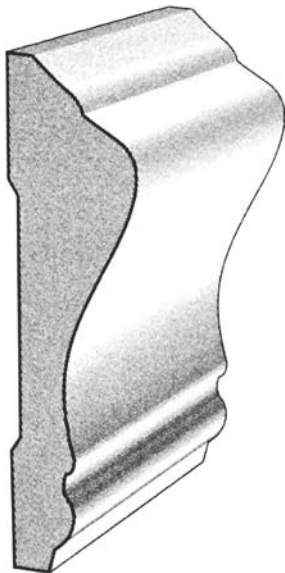

436
1/2 x 2-5/8

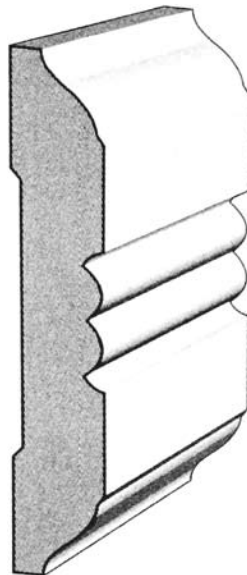

755
11/16 x 2-5/8

** SEE MOULDING INFORMATION PAGE FOR AVAILABILITY **

MISC



909
1/4 X 7/16



912
3/8 X 3/4

ASTRAGAL

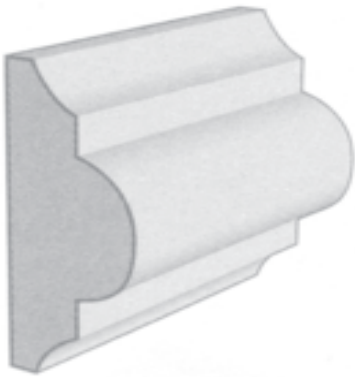

800
11/16 x 1-5/8

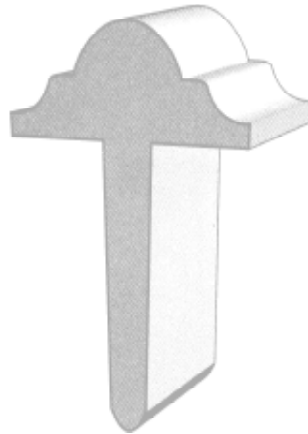

802
1-3/4 T Astragal

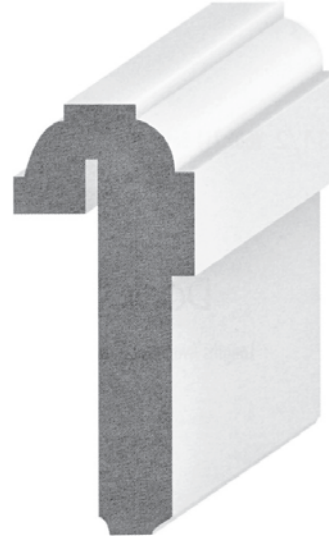

803
1-3/4 T Astragal W/Kerf



Q-LON
Brown or White

SCRIBE & BATTEN



900
3/16 X 3/4



901
1/4 X 3/4



902
1/4 X 1-3/4

** SEE MOULDING INFORMATION PAGE FOR AVAILABILITY **

BAR RAIL

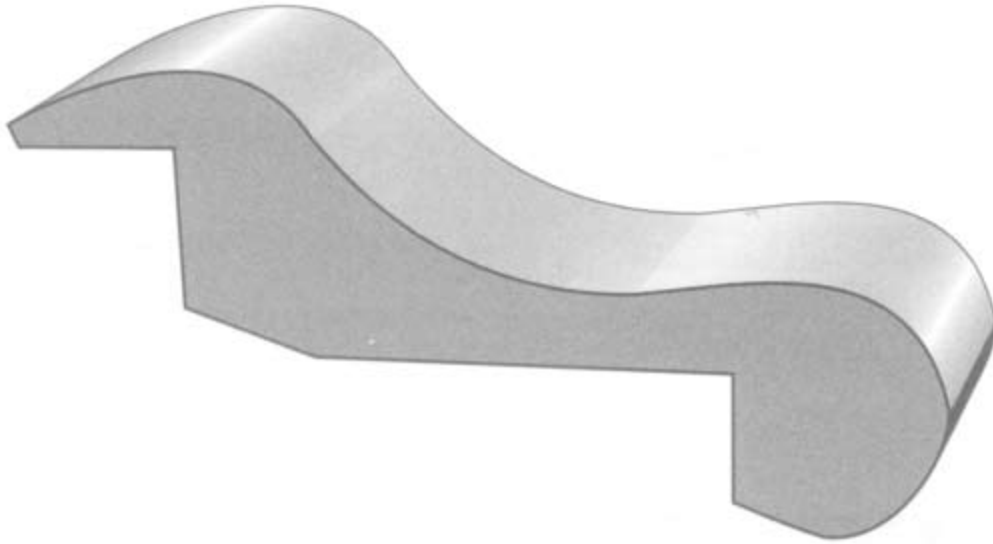

997
2 X 6

PANEL CAP

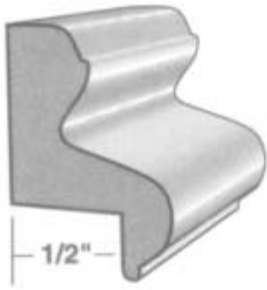

770
13/16 X 1-1/8 (1/2 RABBET)

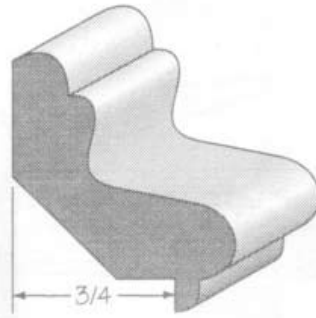

771
1-1/4 (3/4 RABBET)

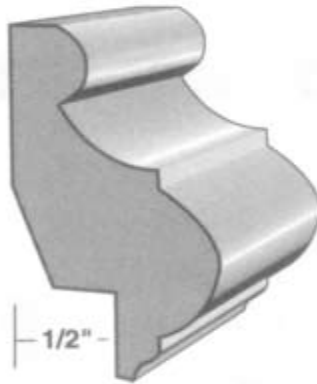

775
1-3/4 (1/2 RABBET)

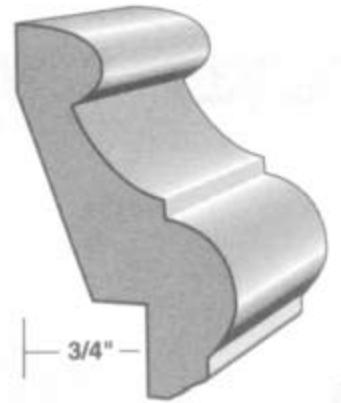

776
13/16 X 1-15/16 (3/4 RABBET)

** SEE MOULDING INFORMATION PAGE FOR AVAILABILITY **

PANEL CAP

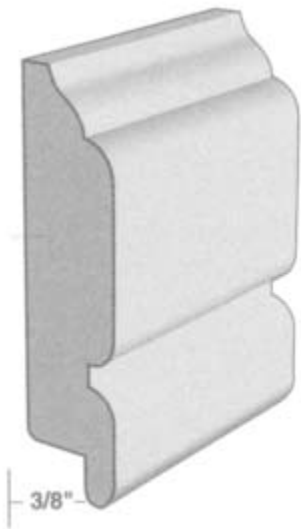

993
9/16 x 2-1/4

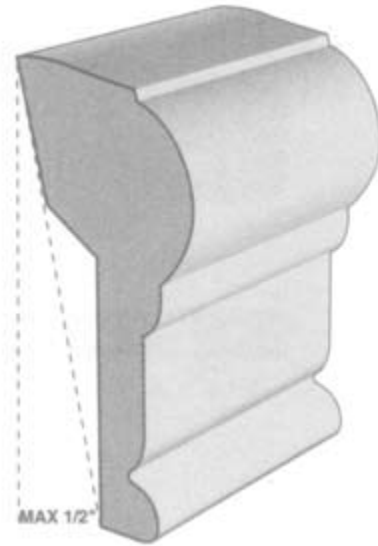

769
1 x 2-1/2 (3/8 RABBET)



767
5/8 x 1-3/8 (1/4 RABT)

T&G WAINSCOT

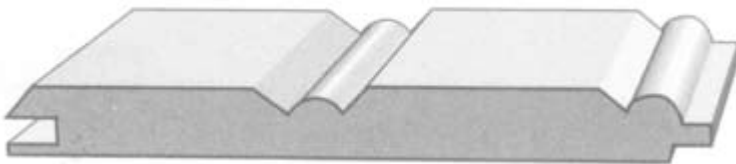

990
3-1/4
Also Stocked in 4 x 8 MDF Sheets

**4 X 8 SHEETS AVAILABLE
2", 3" & 4" ON CENTER**

**** SEE MOULDING INFORMATION PAGE FOR AVAILABILITY ****

FLOOR MOULDING



830
9/16 x 3-1/2

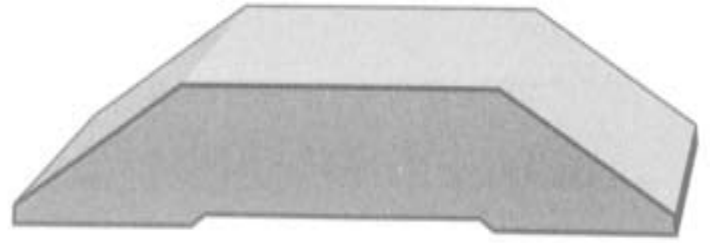

831
3/4 x 3-1/2

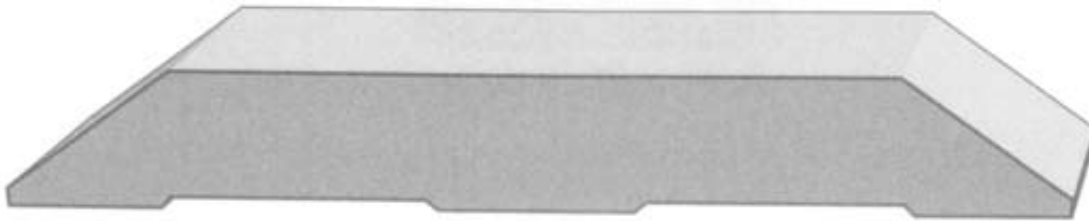

833
3/4 x 5-1/2

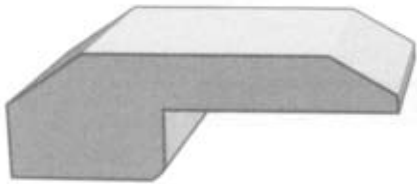

838
5/8 x 2



839
5/8 x 2

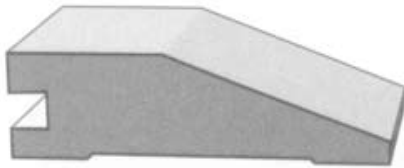

847
3/8 x 2
848
1/2 x 2-1/2

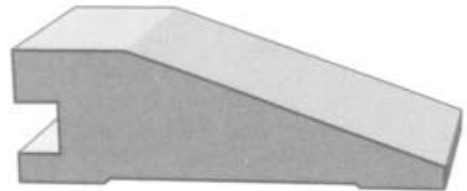

849
3/4 x 2-1/4

** SEE MOULDING INFORMATION PAGE FOR AVAILABILITY **

NOSING

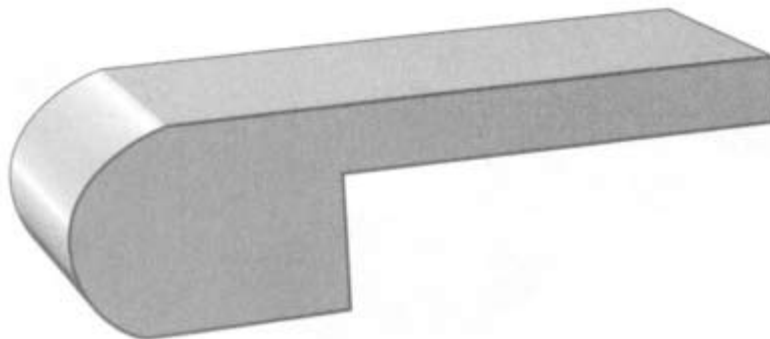

841
1 X 3-1/2 FOR 3/8" FLOOR

842
1 X 3-1/2 FOR 1/2" FLOOR

843
1 X 3-1/2 FOR 3/4" FLOOR

STAIR TREAD



846
1 X 11-3/4

BASE SHOE



100
3/8 x 3/4 Base Shoe



101
1/2 x 3/4 Base Shoe

BRICK & STUCCO MOULD

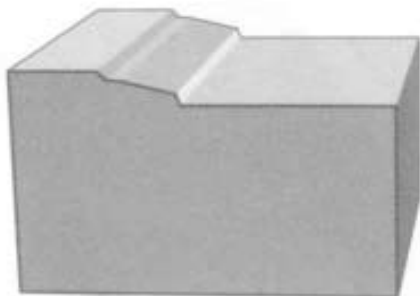

812
1-1/4 X 2



814
3/4 x 1-1/4
OAK* = 7/8 x 1-1/2

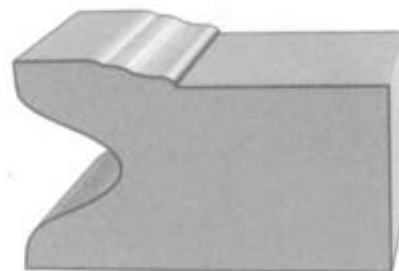

813
1-1/4 X 2 With Stucco Key

** SEE MOULDING INFORMATION PAGE FOR AVAILABILITY **

LATTICE

- 856 5/16 X 1-1/4
- 858 5/16 X 2-1/2
- 859 5/16 X 3-1/2
- 860 1/2 X 1/2
- 863 1/2 X 2-1/2
- 864 1/1 X 3-1/2
- 865 1/2 X 5-1/2
- 870 3/4 X 3/4

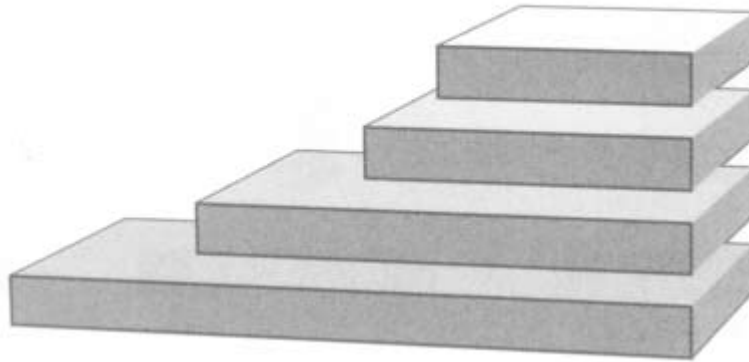

STOOL

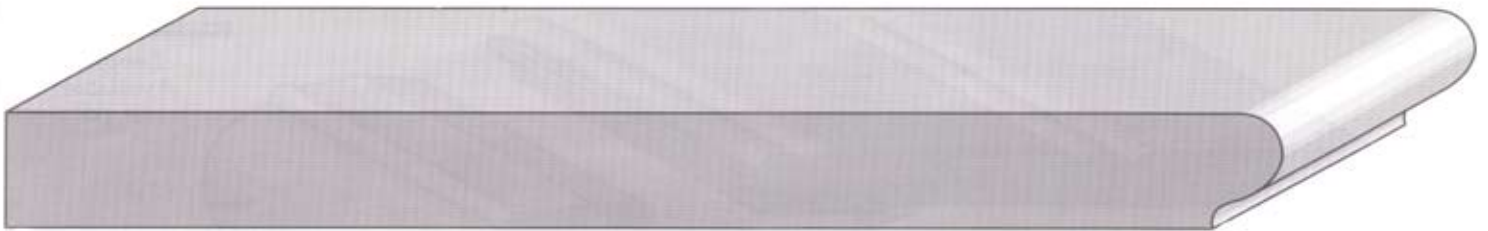

882
11/16 X 4-3/4

883
11/16 X 6-3/4

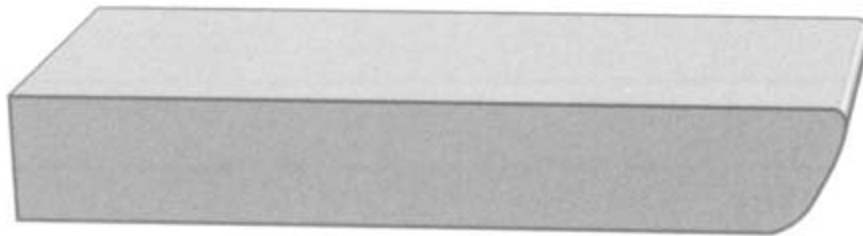

878
11/16 x 4-3/4

880
11/16 x 6-3/4

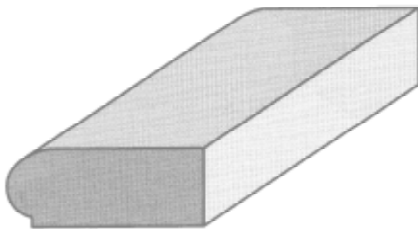

875
7/16 x 1-1/8

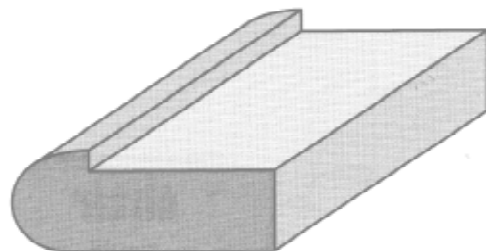

876
1/2 x 1-7/16

** SEE MOULDING INFORMATION PAGE FOR AVAILABILITY **

HAND RAIL & SHOE RAIL

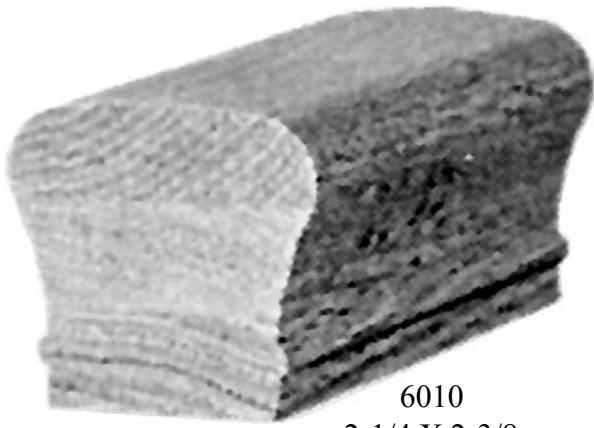

6010
2-1/4 X 2-3/8

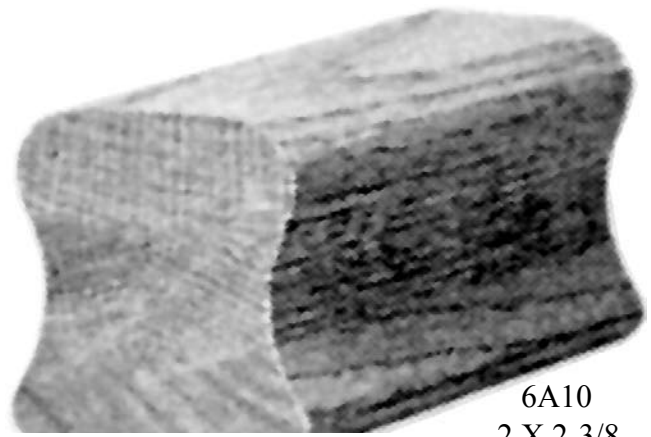

6A10
2 X 2-3/8

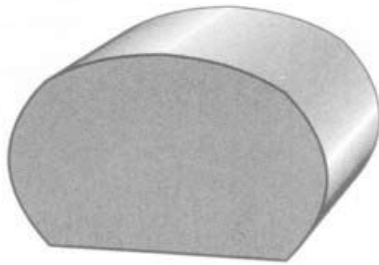

974
2 X 3

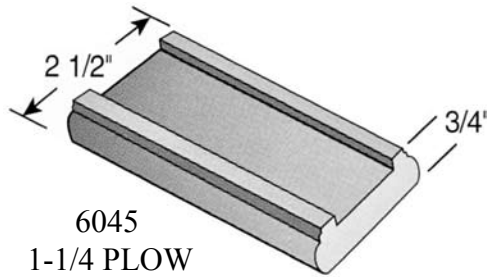

6045
1-1/4 PLOW

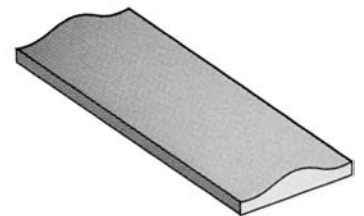

6050
1-1/4 FILLET

STAIR TREADS & PARTS



846



LJ-3127

- BRASS
- POLISHED BRASS
- POLISHED CHROME
- ANTIQUE NICKEL
- OIL RUBBED BRONZE
- SATIN NICKEL
- MATTE BLACK

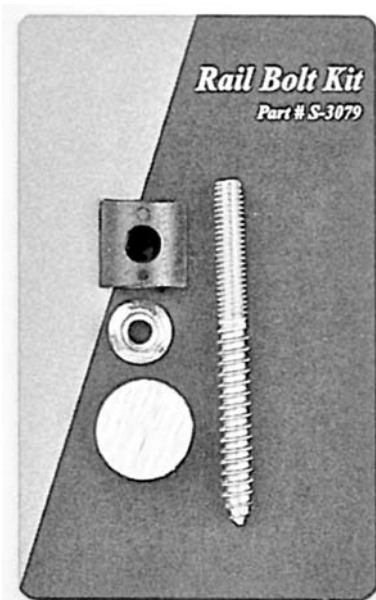

RAIL BOLT KIT
RED OAK & MAPLE



LJ-3012

IMAGES ON THIS PAGE NOT TO SCALE

S4S LUMBER 3/4"

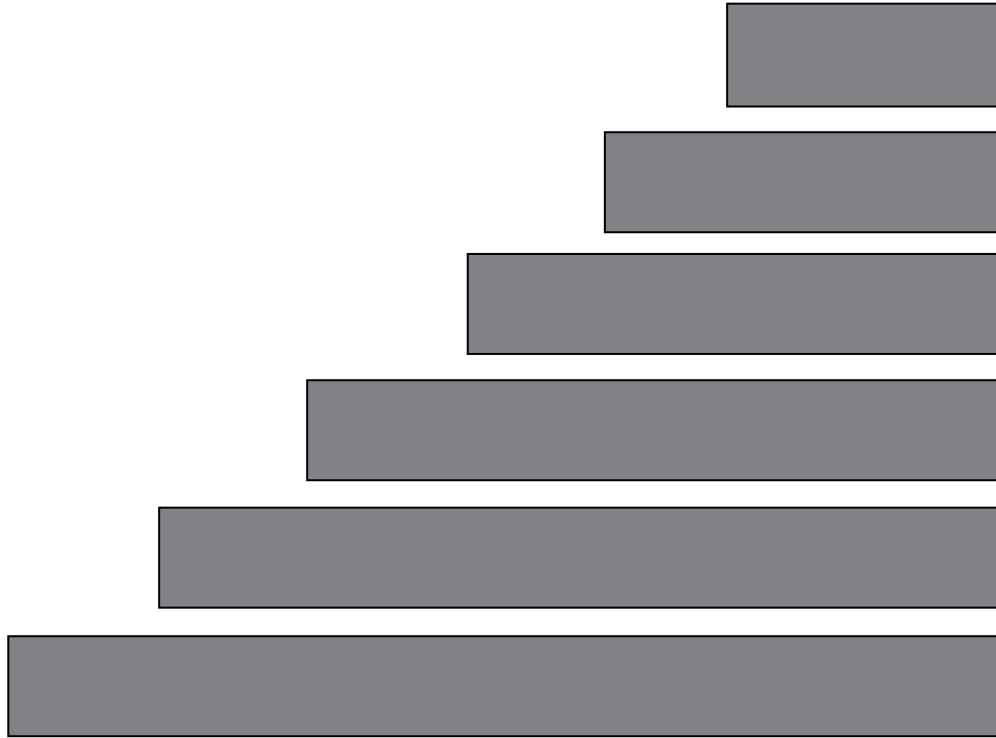

ALDER 1 X 4, 1 X 6, 1 X 8

CHERRY 1 X 8

MAPLE 1 X 2, 1 X 3, 1 X 4, 1 X 6, 1 X 8

MDF 1 X 2, 1 X 3, 1 X 4, 1 X 6, 1 X 8, 1 X 10, 1 X 12

OAK 1 X 2, 1 X 3, 1 X 4, 1 X 6, 1 X 8, 1 X 10, 1 X 12

POPLAR 1 X 2, 1 X 3, 1 X 4, 1 X 6, 1 X 8, 1 X 10, 1 X 12

PLYWOOD

MDF BEAD BOARD

4 X 8 X 1/4" 2" O/C, 3" O/C, 4" O/C

MDF

4 X 8 1/8", 1/4", 1/2", 5/8", 3/4" (3/4" ULTRALIGHT)

4 X 10 1/4", 3/4"

RED OAK

4 X 8 1/8", 1/4", 1/2", 3/4"

OAKUME

4 X 8 5/8", 3/4"

WHITE MELAMINE

4 X 8 1/4" (ONE SIDED), 1/2", 3/4" (TWO SIDED)

BLOCKS

PB1 7/8 x 2-3/4 With Edge Detail
PB3 7/8 x 3-3/4 With Edge Detail
740-MDF 1 x 4-1/2 With Edge Detail

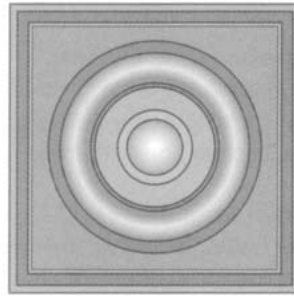

PB6 7/8 x 2-3/4 No Edge Detail
PB8 7/8 x 3-3/4 No Edge Detail

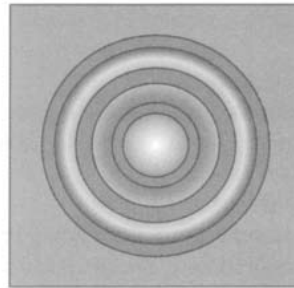

10BB 7/8 x 2-3/4 x 6
12BB 7/8 x 3-3/4 x 6



6BB 7/8 x 2-3/4 x 6 With Edge Detail
8BB 7/8 x 3-3/4 x 6 With Edge Detail



MOULDING INDEX PAGE

Profile #	Page#	Profile #	Page#	Profile #	Page#	Profile #	Page#	Profile #	Page#
6BB	53	220	14	511	25	676	40	859	49
8BB	53	255	18	512	28	680	40	860	49
10BB	53	302	20	513	28	681	40	863	49
12BB	53	306	20	514	28	682	40	864	11&49
100	48	322	20	515	30	683	40	865	18&49
101	48	324	20	516	32	685	40	870	49
107	9	336	23	518	33	694	40	875	49
111	9	337	23	519	35	695	40	876	49
115	9	340	20	520	26	699	40	878	49
116	9	341	20	530	26	700	42	880	49
118	9	343	20	531	26	702	42	882	49
123	9	345	20	532	26	720	42	883	49
127	9	346	20	539	27	722	42	900	44
128	17	350	20	542	30	730	42	901	44
132	10	356	23	543	34	736	42	902	44
133	10	360	20	544	36	754	43	907	44
137	10	365	22	550	30	755	43	908	44
142	10	371	22	551	32	760	43	909	44
143	12	374	23	552	37	762	43	911	44
146	10	380	22	555	26	767	46	912	44
153	10	381	23	557	31	769	46	919	42
154	14	400	22	560	31	770	45	920	42
155	16	401	22	570	27	771	45	925	42
160	12	410	21	572	31	775	45	930	41
161	15	415	21	573	33	776	45	932	41
162	19	417	24	590	29	800	44	933	41
165	11	420	22	591	29	802	44	974	50
166	13	421	24	623	39	803	44	990	46
167	13	422	22	624	39	812	48	993	46
170	12	425	21	635	39	813	48	RM12	38
171	13	436	43	640	39	814	48	RM34	38
173	13	447	23	651	39	830	47	RM38	38
180	11	450	22	653	39	831	47	DIL	38
184	17	470	21	654	39	833	47	DIS	38
185	18	493	24	657	39	838	47	PB1	53
189	11	494	24	658	39	839	47	PB3	53
193	14	495	24	660	41	842	48	OVOLO	39
194	16	498	24	661	41	843	48		
196	17	500	25	662	41	846	48		
200	12	502	25	663	41	847	47		
202	15	503	25	670	40	848	47		
210	12	504	28	671	40	849	49		
212	13	509	25	672	40	856	49		
...		

NOTES



*North County's Premier Moulding and
Decorative Wood Products Supplier*

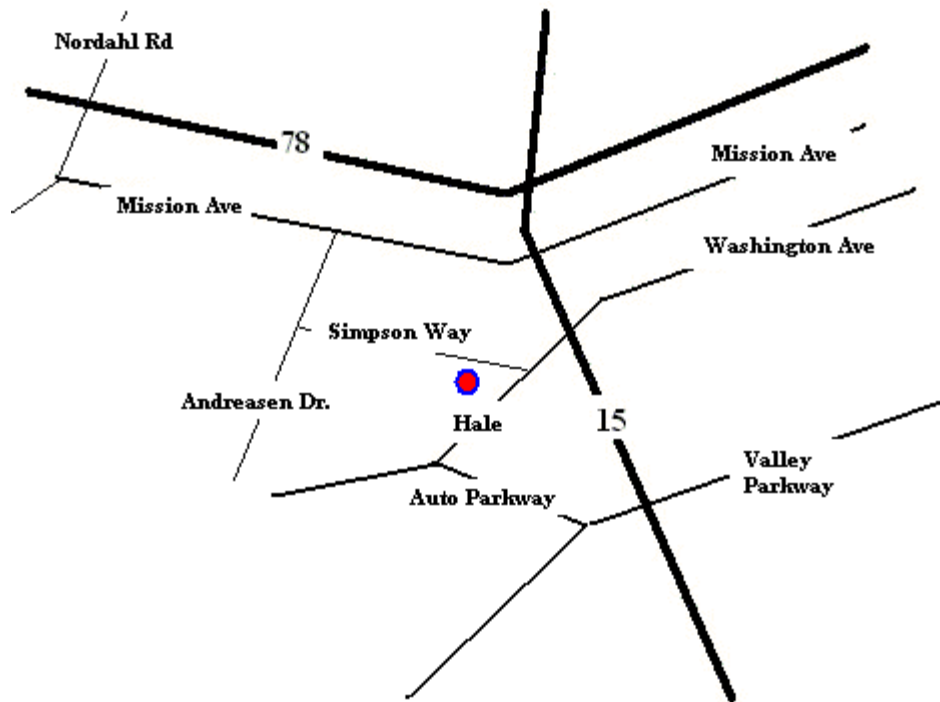

Showcase Moulding, Inc.

1233 Simpson Way

Escondido, CA 92029

760-735-8746 / 760-735-8776 Fax

www.showcasemoulding.com